

## REPAIR SHEET

BRAND

**RYOBI**

DESCRIPTION

MODEL NO.

**TS1144**

# 7-1/4 in. Compound Miter Saw

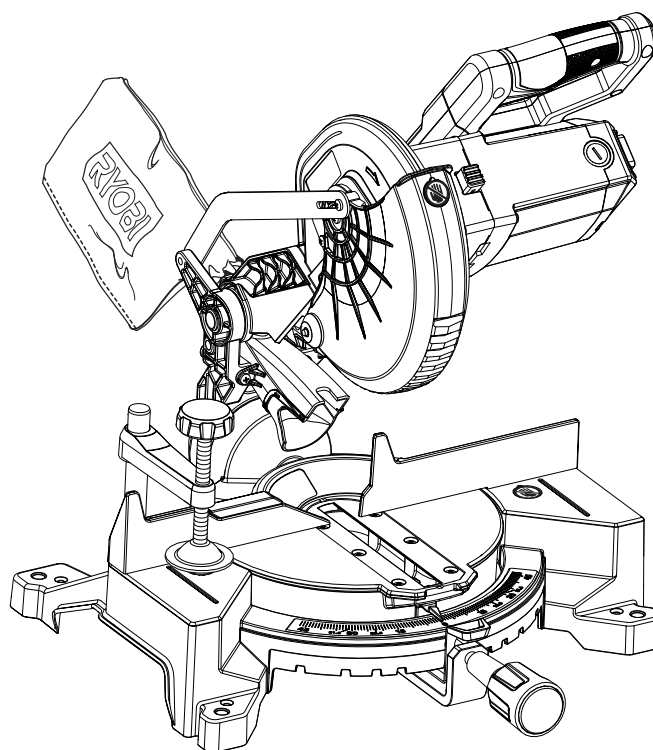

**ONE WORLD TECHNOLOGIES, INC.**

P.O. Box 1288, Anderson, SC 29622 ■ 1-800-525-2579 ■ [www.ryobitools.com](http://www.ryobitools.com)

8-3-21 (Rev:03)

*The model number and manufacturing location will be found on a label attached to the product. Always mention this information in all communications regarding this product and when ordering parts.*

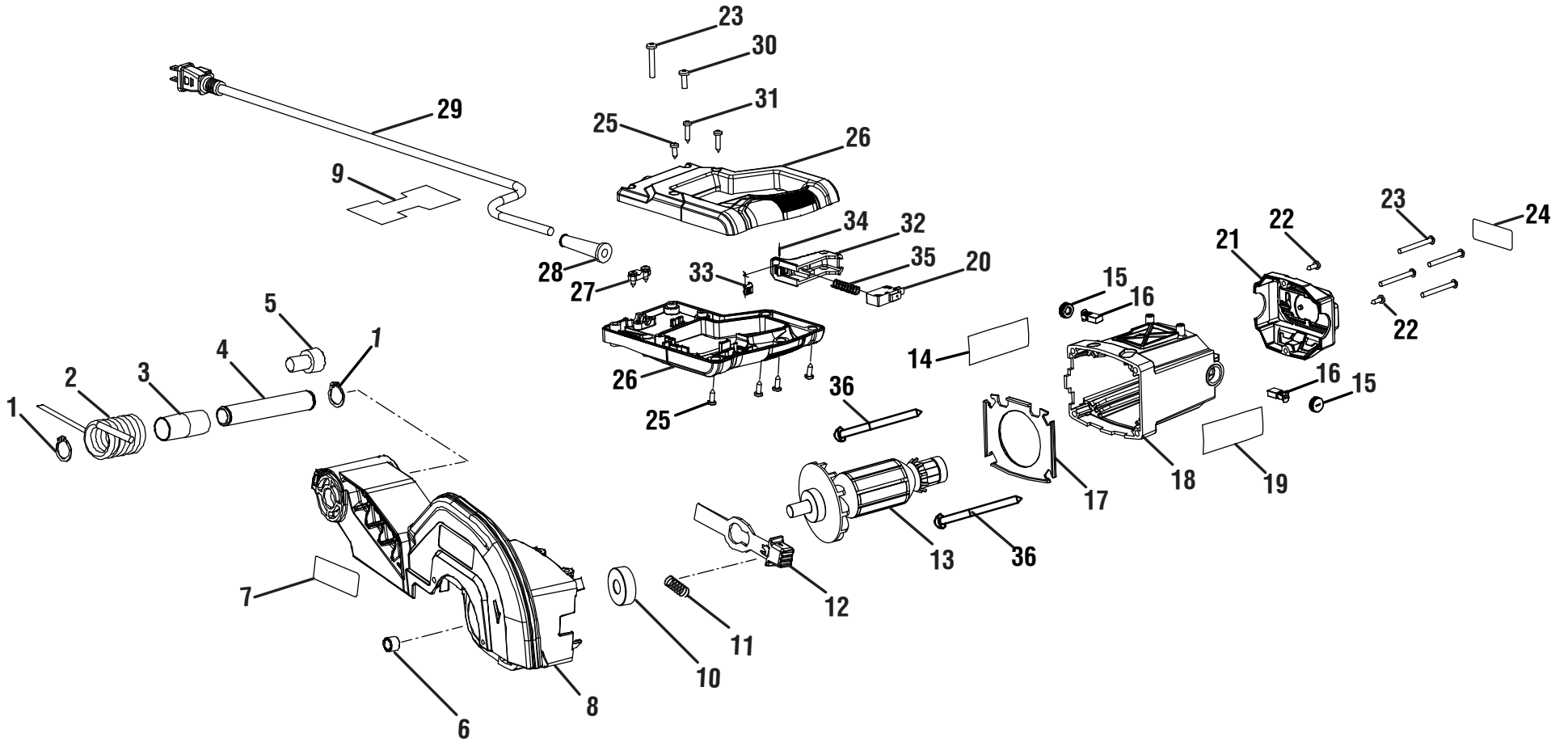

**PARTS LIST – FIGURE A**

KEY NO.	PART NO.	DESCRIPTION	QTY.
1	089240011011	Spindle Clip	2
2	089240027020	Torsion Spring	1
3	089240011010	Shaft Sleeve	1
4	089240027022	Pivot Shaft	1
5	089240011017	Screw (M8 x 12 mm, Pan Hd.)	1
6	089240011075	Oil Bearing (13 x 9 x 10)	1
7	089240011904	Upper Guard Logo Label	1
8	089240027705	Upper Blade Guard Assembly (Inc. Key Nos. 6-7)	1
9	089240034908	Cordwrap Label	1
10	089240027045	Bearing (6201-2RS)	1
11	089240011066	Compression Spring	1
12	089240026706	Spindle Lock Assembly	1
13	089240027707	Armature Assembly	1
14	089240026901	Data Label	1
15	089240011057	Brush Cover	2
16	089240011058	Brush	2
17	089240027055	Baffle	1
18	089240027708	Motor Housing w/Field Assembly (Inc. Key Nos. 14 & 19)	1
19	089240027902	Warning Label	1

KEY NO.	PART NO.	DESCRIPTION	QTY.
20	089240027703	Trigger Assembly (Inc. Key Nos. 32-35)	1
21	089240027063	Endcap (Inc. Key No. 24)	1
22	089240027064	Screw (ST4.2 x 16 mm)	2
23	089240011039	Screw (M5 x 30 mm)	5
24	089240027905	Endcap Logo Label	1
25	089240011068	Screw (M4.2 x 13 mm)	5
26	089240027704	Handle Assembly	1
27	089240011036	Cord Clamp	1
28	089240011034	Bend Relief	1
29	089240027026	Power Cord (Inc. Key No. 9)	1
30	089240027029	Screw (M5 x 14 mm)	1
31	089240027030	Screw (M4.2 x 19 mm)	2
32	089240027036	Trigger	1
33	089240027039	Switch Lock Block	1
34	089240034001	Pin	1
35	089240027035	Compression Spring	1
36	089240027049	Screw (M4.2 x 55 mm)	2
	<b>Not Shown:</b>		
	995000692	Operator's Manual (089240034904)	

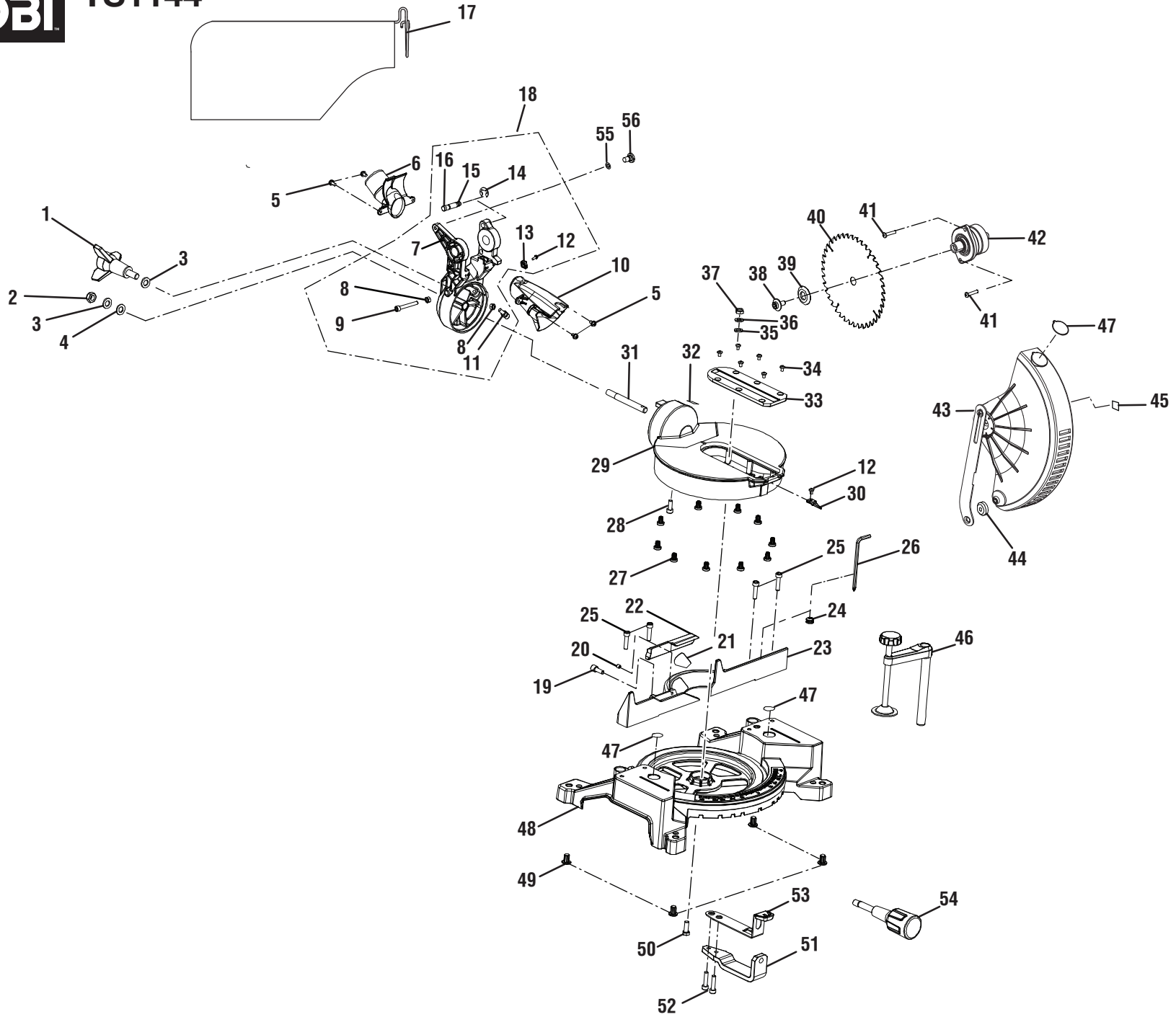

**PARTS LIST – FIGURE B**

KEY NO.	PART NO.	DESCRIPTION	QTY.
1	089240026711	Bevel Lock Knob w/Washer	1
2	089240011097	Lock Nut (M10)	1
3	089240011095	Washer (OD20 x ID10.5 mm x 2t)	2
4	089240011096	Washer (OD18.8 x ID10 mm x 1t)	1
5	089240027005	Screw (M4 x 12 mm)	4
6	089240027006	Dust Chute Outlet	1
7	089240027007	Bevel Knuckle	1
8	089240011093	Nut w/Washer (M6)	2
9	089240027009	Screw (M6 x 35 mm)	1
10	089240027010	Dust Chute Inlet	1
11	089240011110	Screw (M6 x 20 mm)	1
12	089240011130	Screw (M4 x 8 mm)	2
13	089240011109	Bevel Indicator	1
14	089240027002	Clip (ø5)	1
15	089832002019	Head Lock Pin	1
16	089240011015	O-Ring (4.5 x 1.8)	1
17	089240027702	Dust Bag Assembly	1
18	089240027701	Bevel Arm Assembly (Inc. Key Nos. 7-9 & 11-16)	1
19	089240027110	Fence Lock Screw	1
20	089240027109	Screw (M6 x 10 mm)	1
21	089240027906	Sliding Fence Warning Label	1
22	089240027107	Sliding Fence	1
23	089240027715	Miter Fence (Inc. Key No. 21)	1
24	089240011091	Spanner Holder	1
25	089240011088	Screw (M6 x 25 mm)	4
26	089240011090	Hex Key Wrench	1
27	089240011141	Rubber Feet	10
28	089240011113	Screw (M6 x 16 mm)	1

KEY NO.	PART NO.	DESCRIPTION	QTY.
29	089240027710	Miter Table Assembly (Inc. Key No. 32)	1
30	089240027099	Miter Indicator	1
31	089240011111	Shaft	1
32	089240071903	Bevel Scale Label	1
33	089240027096	Throat Plate	1
34	089240011120	Screw (M4 x 8 mm)	6
35	089240011117	Washer (OD22 x ID8 mm x 3t)	1
36	089240011116	Washer (OD16 x ID8 mm x 1.6t)	1
37	089240011115	Lock Nut (M8)	1
38	089240034007	Blade Screw (M8 x 16 mm)	1
39	089240011086	Blade Washer	1
40	089240027904	Blade (24t)	1
41	089240011080	Screw (M5 x 16 mm)	2
42	089240011709	Output Spindle Assembly	1
43	089240027716	Lower Blade Guard Assembly (Inc. Key Nos. 44-45 & 47)	1
44	089240011026	Lower Guard Wheel	1
45	089240027903	Blade Screw Direction Label	1
46	089240027717	Work Clamp Assembly	1
47	089240034910	No Hands Label	3
48	089240027713	Base Assembly (Inc. Key No. 47)	1
49	089240011140	Rubber Feet	4
50	089240011139	Screw (M8 x 25 mm)	1
51	089240027115	Miter Support Arm	1
52	089240011088	Screw (M6 x 25 mm)	2
53	089240027712	Miter Detent Spring Assembly	1
54	089240027711	Miter Lock Handle Assembly	1
55	089240011008	Spring Washer	1
56	089240011029	Plate Screw	1

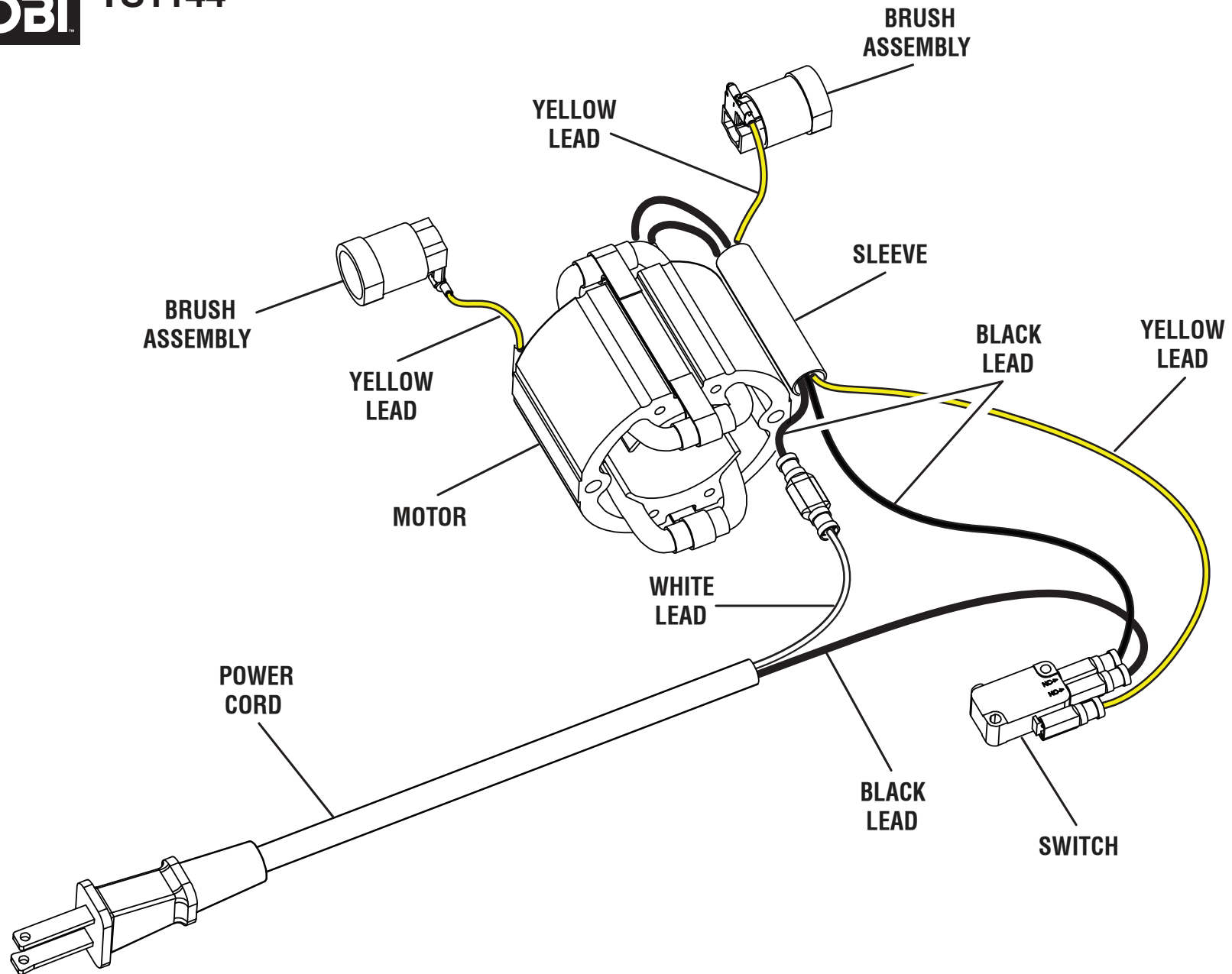

**WIRING DIAGRAM**