

GENERAL SAFETY WARNINGS

WARNING:

Read all safety warnings and all instructions. Failure to follow the warnings and instructions may result in electric shock, fire and/or serious injury.

READ ALL INSTRUCTIONS

- **Know your product.** Read operator's manual carefully. Learn its applications and limitations, as well as the specific potential hazards related to this product. Following this rule will reduce the risk of serious personal injury.
- **The maximum weight of all the items placed on this cabinet must not exceed 330 lbs.**
- **Do not exceed the maximum weight capacity for the shelves, side walls or cubicles.**
- **This is a cabinet. Do not use for any other purpose than supporting tools or products.** Do not use as a seat, ladder, or standing platform.
- **Keep the area around the cabinet clean and well lit.** Cluttered or dark areas invite accidents.
- **Mount the cabinet in a dry, indoor place protected from wet conditions.**
- **Keep cabinet dry, clean, and free from oil and grease.**
- **Do not use the cabinet if it is damaged or broken.** A damaged or broken cabinet may not mount securely and/or it might not provide adequate support for the items stored on it.
- **When servicing this product, use only identical replacement parts.** Use of unauthorized parts may create a risk of injury.
- **Mount the cabinets to sound structural supports. NEVER mount the cabinets to drywall or plaster without the mounting fastener going into a structural support. ALWAYS use concrete anchors when installing cabinets into concrete, brick, or other masonry.** Failure to properly mount the cabinet could result in a falling hazard that can cause death or serious personal injury.
- **Mount the cabinet on smooth and flat surfaces capable of bearing the weight of cabinet and the items stored on it.**
- **Use extra care when mounting the unit. Keep proper footing and balance at all times.**
- **Ensure the cabinet is securely mounted.** Make sure it does not rock, slide, or move before storing products or tools.
- **Always wear eye protection with side shields marked to comply with ANSI Z87.1 during installation.** Following this rule will reduce the risk of serious personal injury.
- **Do not allow children or untrained individuals to use this cabinet.**
- **Always get help when lifting, moving, and mounting the cabinet.** When lifting, hold the cabinet close to your body. Bend your knees so you can lift with your legs, not your back.
- **SAVE THESE INSTRUCTIONS.** Refer to them frequently and use them to instruct other users. If you loan someone this product, also loan these instructions.

SYMBOLS

The following signal words and meanings are intended to explain the levels of risk associated with this product.

SYMBOL	SIGNAL	MEANING
	DANGER:	Indicates a hazardous situation, which, if not avoided, will result in death or serious injury.
	WARNING:	Indicates a hazardous situation, which, if not avoided, could result in death or serious injury.
	CAUTION:	Indicates a hazardous situation, that, if not avoided, may result in minor or moderate injury.
	NOTICE:	(Without Safety Alert Symbol) Indicates information considered important, but not related to a potential injury (e.g. messages relating to property damage).

Some of the following symbols may be used on this product. Please study them and learn their meaning. Proper interpretation of these symbols will allow you to operate the product better and safer.

SYMBOL	NAME	DESIGNATION/EXPLANATION
	Safety Alert	Indicates a potential personal injury hazard.
	Read Operator's Manual	To reduce the risk of injury, user must read and understand operator's manual before using this product.
	Eye Protection	Always wear eye protection with side shields marked to comply with ANSI Z87.1.

FEATURES

PRODUCT SPECIFICATIONS

See Figure 1.

Maximum Weight Capacity

Entire cabinet	330 lbs.
Top Shelf	77 lbs.
Bottom Shelf	143 lbs.
Cubicles	22 lbs. per cubicle
Side Wall	11 lbs. per side wall

INSTALLATION

WARNING:

To reduce the risk of injury, do not attempt to use this product until you have read thoroughly and understand completely this operator's manual and the operator's manual for any power tools used.

TOOLS NEEDED (NOT INCLUDED)

AC or DC Drill, Hammer, Level, Pencil, Screws (#10 x 2-1/2 in.) [4], Concrete Anchors (4), and Phillips Screwdriver

MOUNTING THE CABINET

See Figures 2 - 5.

WARNING:

Only install screws and anchors into sound structural supports (such as studs and concrete) in areas where no electrical wires, utility cables, pipes, or other obstructions are located. Failure to follow these instructions can result in death, electrical shock, or other serious personal injury.

WARNING:

Do not lift the product without help. Hold it close to your body. Keep your knees bent and lift with your legs, not your back. Ignoring these precautions can result in back injury.

- Locate the wooden studs behind your wall.
 - Using a pencil and a level, mark four screw holes. The top two screw holes should be 16 in. apart on studs. The bottom screw holes should be 10.4 inches below the top screws.
 - Using an AC or DC drill make four pilot holes slightly smaller than the screws.
 - Using a Phillips screwdriver install the screws through each of the pilot holes. **Leave the head of the screw approximately 1/4 in. off the wall.**
 - **NOTE:** Use screws and concrete anchors when installing the cabinet into concrete. Use your fingers to press the anchor into the pilot hole. Tap the head of the anchor lightly with the hammer until it is flush with the wall. Then install the screws.
 - With the help of at least one other person, carefully lift the cabinet and align the keyholes on the back with the screws in the walls.
 - **NOTE:** If necessary, open the door for the bottom shelf so you can see the keyholes from the front of the cabinet.
 - Place the wide portion of each keyhole over the head of each screw.
 - To lock the cabinet in place, slide the cabinet down until the screws are inside the narrow portions of each keyhole.
 - **NOTE:** Check cabinet installation by verifying it is level, plumb, and secure to the wall.
- To unmount the cabinet:**
- Remove all of the items stored on the cabinet.
 - With the help of at least one other person, carefully lift the cabinet until the screws are inside the wide portions of each keyhole and remove the cabinet from the wall.

ONE WORLD TECHNOLOGIES, INC.

P.O. Box 1288, Anderson, SC 29622 • Phone 1-800-525-2579
 États-Unis, Téléphone 1-800-525-2579 • USA, Teléfono 1-800-525-2579

www.ryobitools.com

STH401

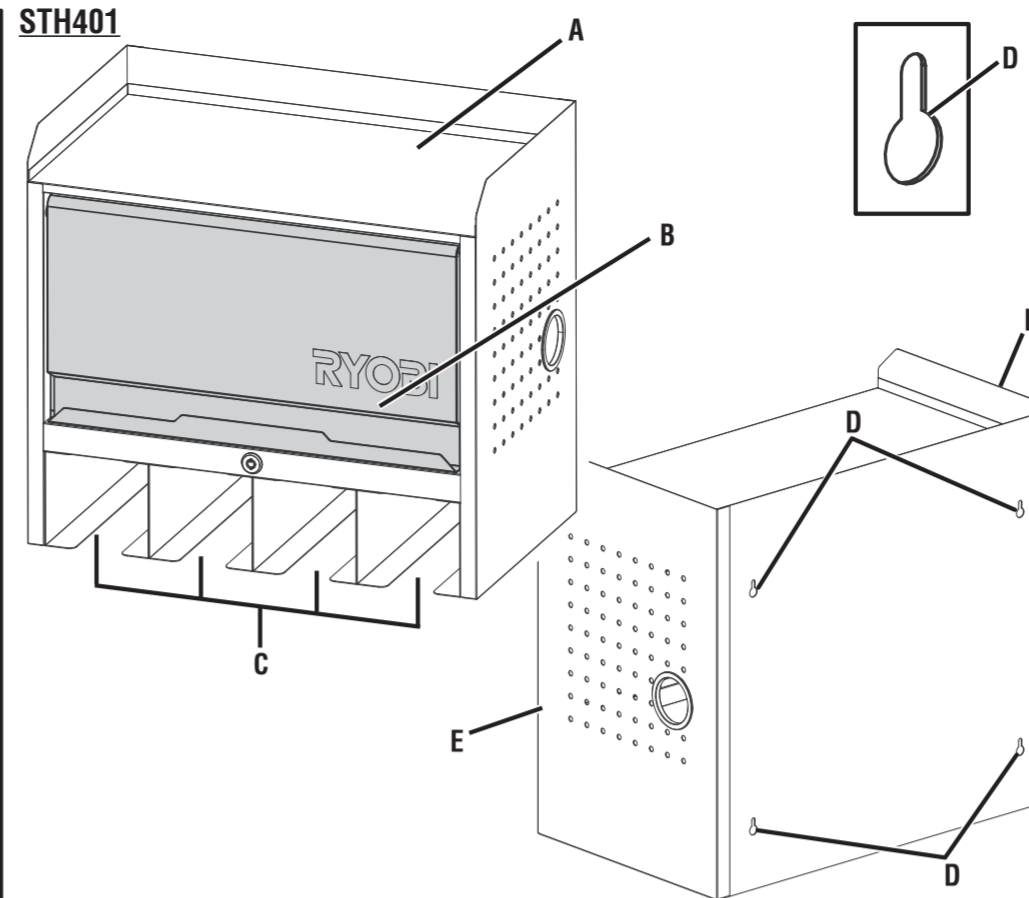

A - Top shelf (tablette du haut, estante superior)
 B - Bottom shelf (door closed) [tablette du bas (porte fermée), estante inferior (puerta cerrada)]
 C - Cubicle (cabinet, cubículo)
 D - Key hole hanger (trou de serrure pour la suspension, colgador tipo bocallave)
 E - Side wall (paroi latérale, pared lateral)

Fig. 1

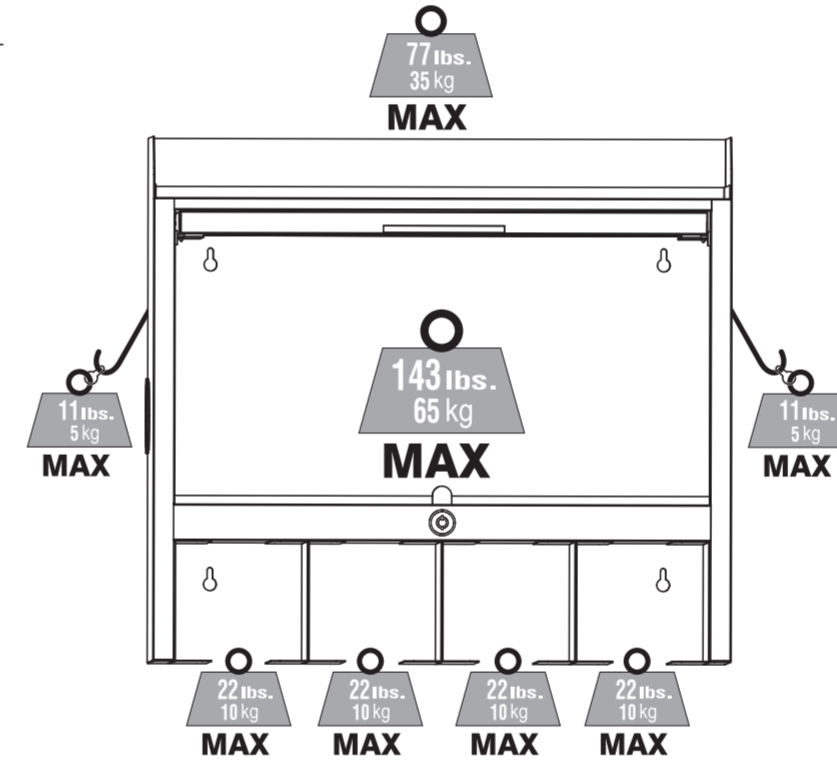
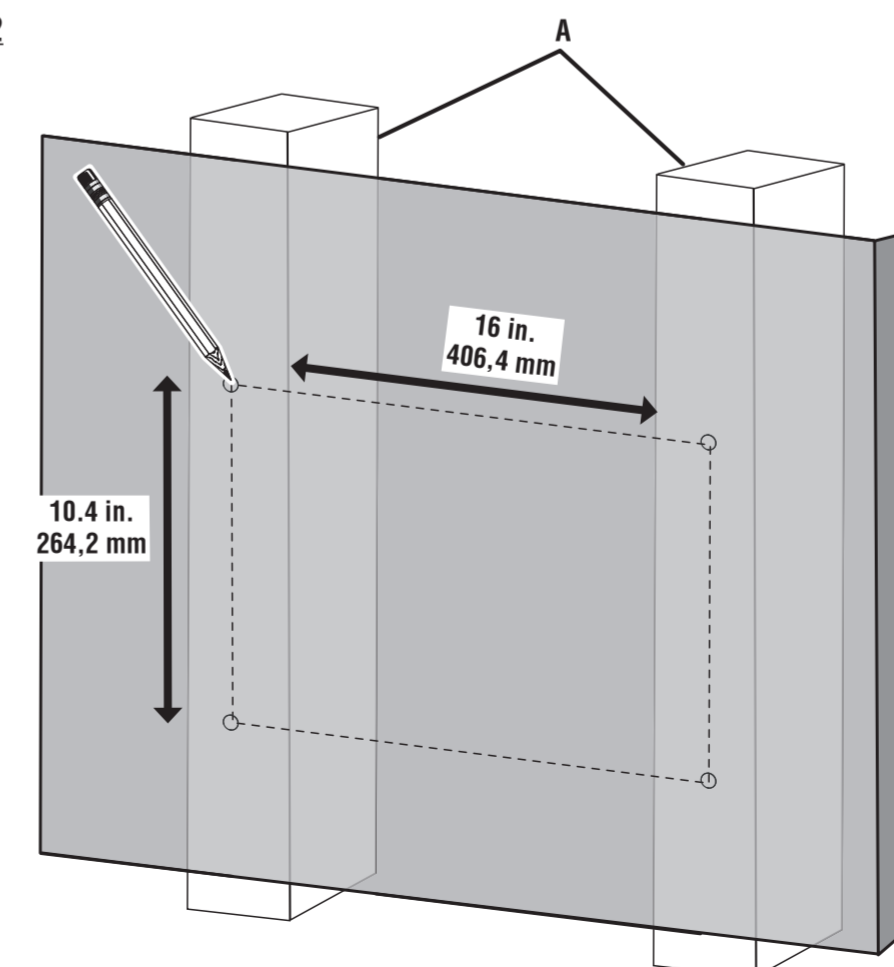
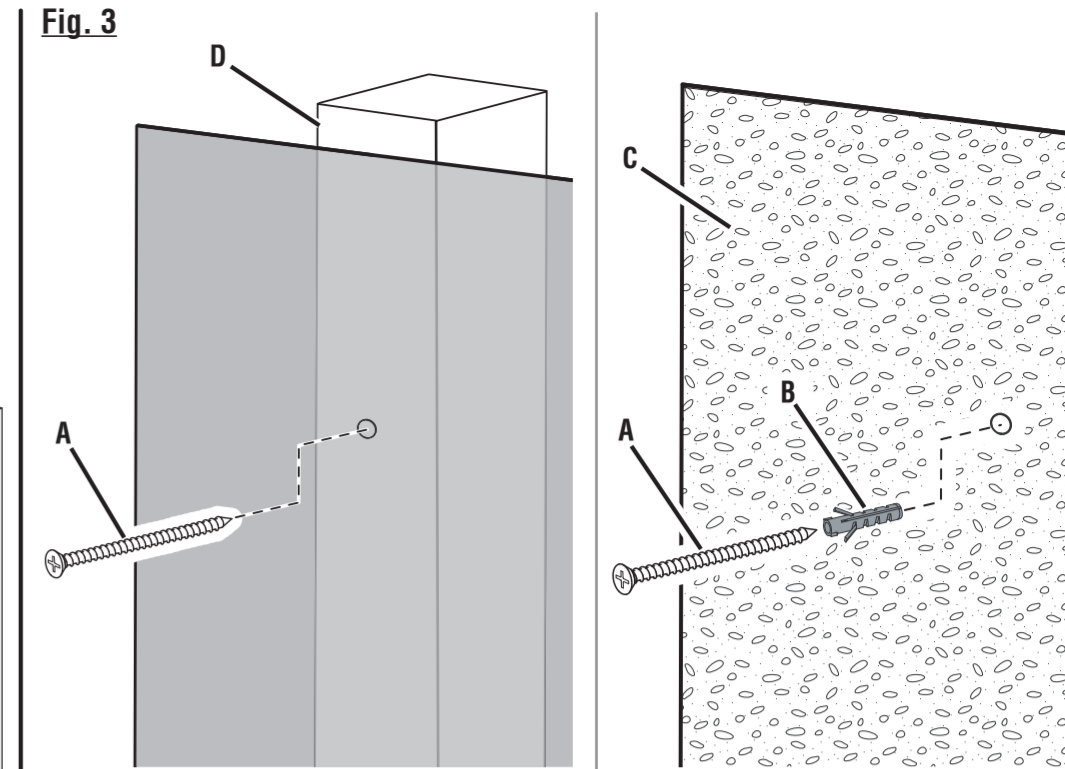

Fig. 2



A - Stud (montant, montante)

Fig. 3



A - Screw (vis, tornillo)
 B - Concrete anchor (ancrage pour béton, taco para hormigón)
 C - Concrete (béton, hormigón)
 D - Stud (montant, montante)

Fig. 4

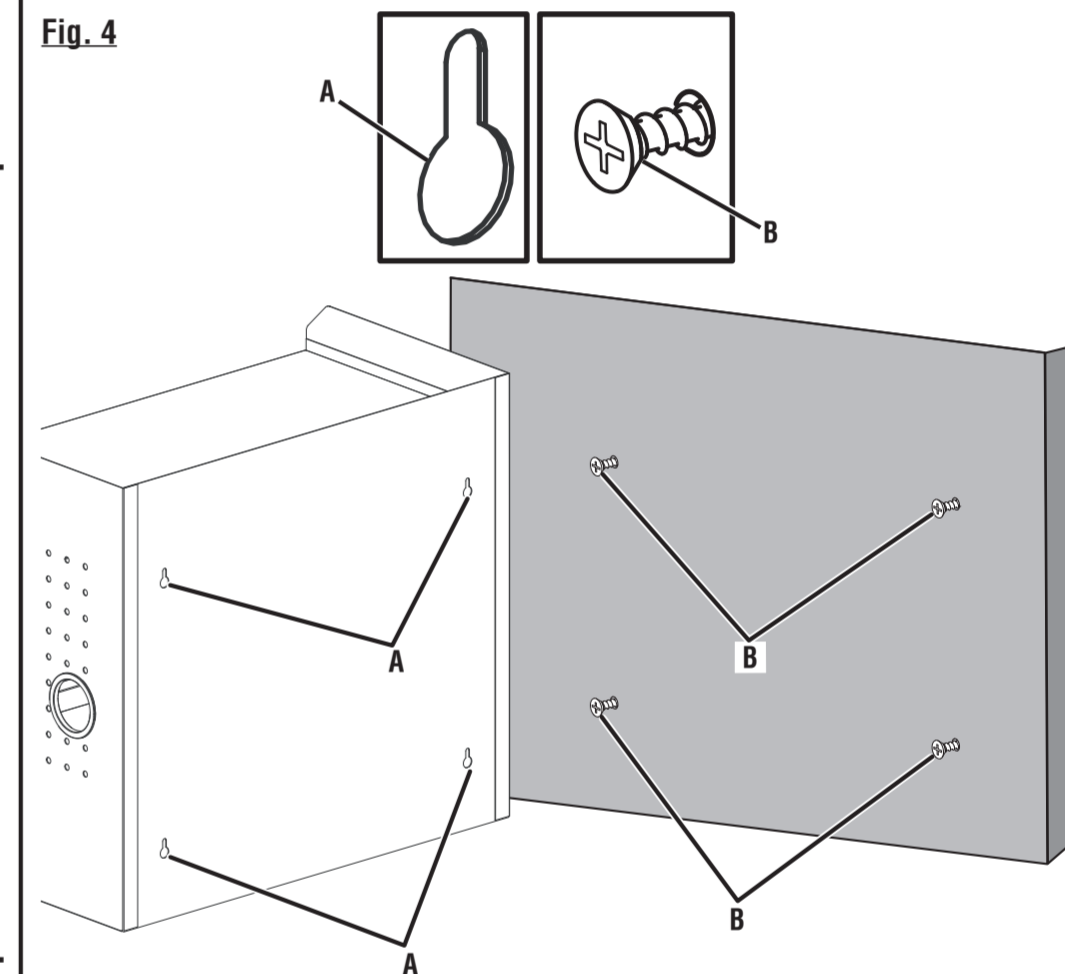

A - Key hole hanger (trou de serrure pour la suspension, colgador tipo bocallave)
 B - Screw (vis, tornillo)

Fig. 5

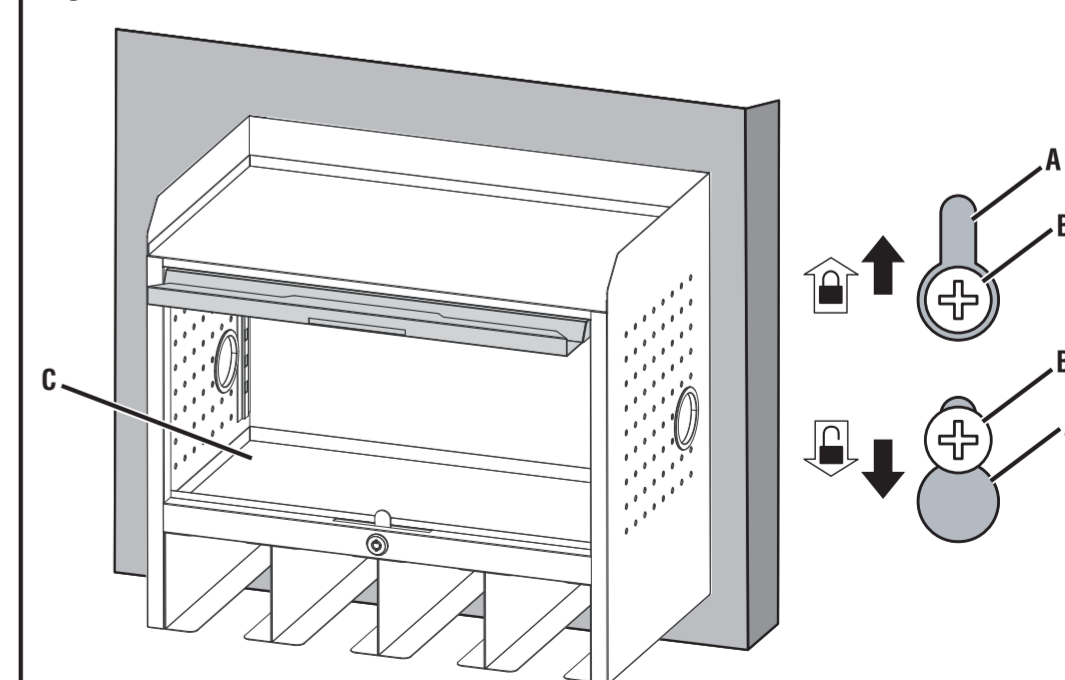

A - Key hole hanger (trou de serrure pour la suspension, colgador tipo bocallave)
 B - Screw (vis, tornillo)
 C - Bottom shelf (door open) [tablette du bas (porte ouverte), estante inferior (puerta abierta)]

