

# RY906500 QUICK REFERENCE GUIDE

## ⚠ WARNING:

This Quick Reference Guide is not a substitute for reading the operator's manual. To reduce the risk of injury or death, user must read and understand operator's manual before using this product. All page references refer to the operator's manual.

## IMPORTANT!

### ⚠ WARNING:

Do not connect to a building's electrical system unless the generator and transfer switch have been properly installed and the electrical output has been verified by a qualified electrician. The connection must isolate the generator power from utility power and must comply with all applicable laws and electrical codes.

### ⚠ DANGER

Using a generator indoors **CAN KILL YOU IN MINUTES**. Generator exhaust contains carbon monoxide. This is a poison you cannot see or smell.



**NEVER** use inside a home or garage, **EVEN IF** doors and windows are open.



Only use **OUTSIDE** and far away from windows, doors, and vents.

## TOOLS NEEDED

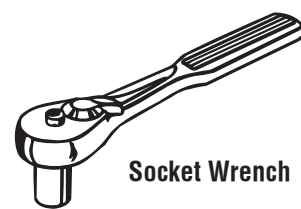

Socket Wrench



Combination Wrench

## FIRST TIME ASSEMBLY

### 1 Install the feet (see page 11).

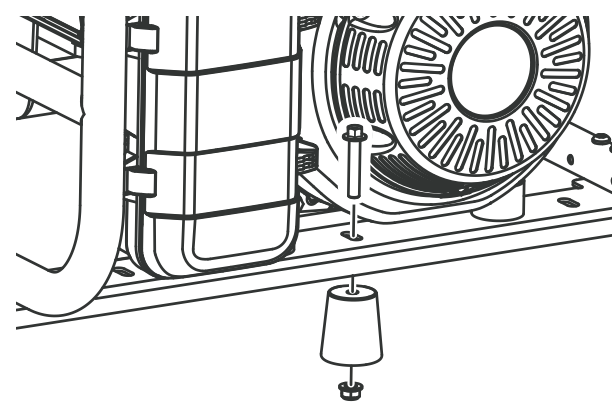

### 2 Install the wheels (see page 12).

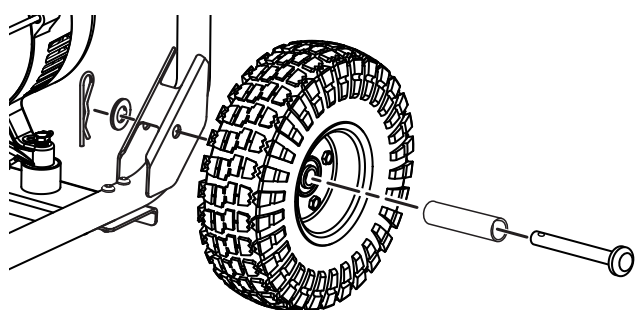

### 3 Raise the handle (see page 13).

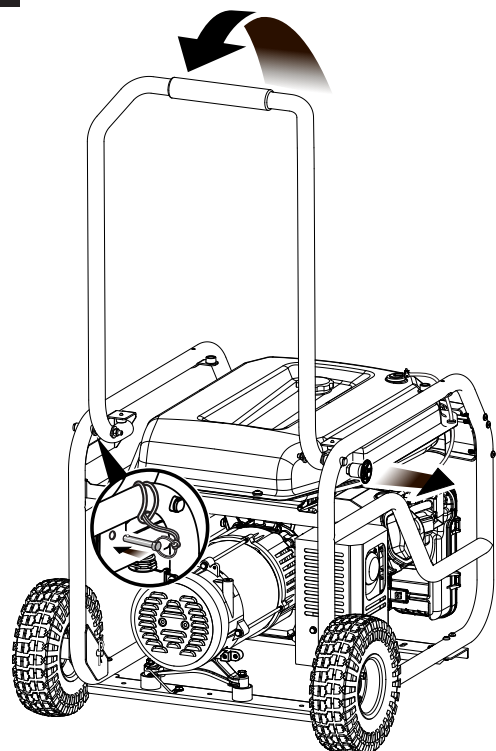

### 4 Secure the handle (see page 13).

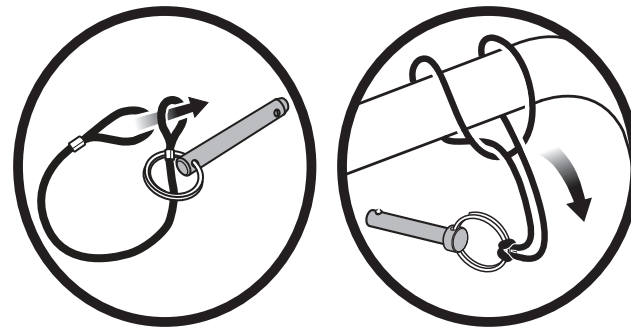

### 5 Add entire bottle of lubricant provided to the generator (see page 13).

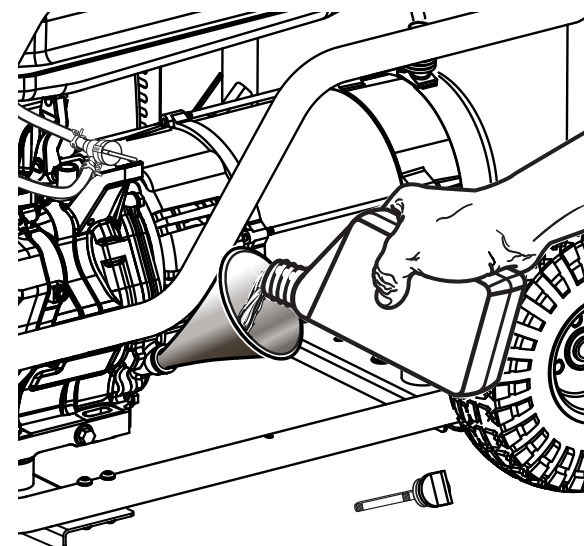

Set unit on flat surface so engine is level. Remove dipstick, wipe clean, put back in hole (but don't screw in) and check lubricant level.

## STARTING THE UNIT

### 1 Add fuel (see page 13).

### NOTICE:

Do not use E15 or E85 fuel in this product. Only use unleaded gasoline containing up to 10% ethanol. It is a violation of federal law and will damage the unit and void your warranty.

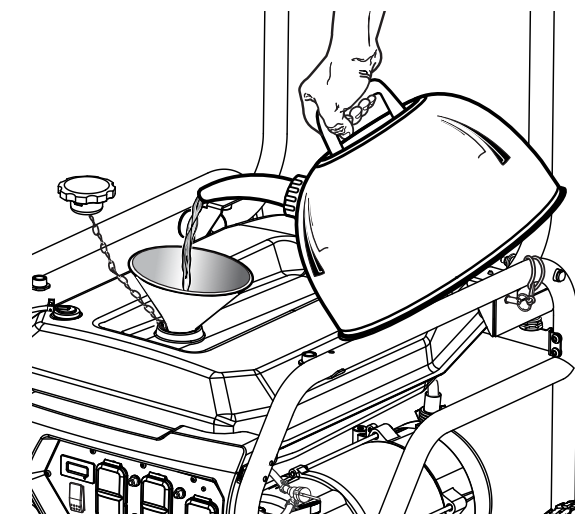

This is a 4-cycle engine. Do not mix fuel and lubricant together.

Mix fuel stabilizer with gasoline according to manufacturer's directions prior to filling the tank.

### 2 Turn the fuel valve to ON (see page 14).

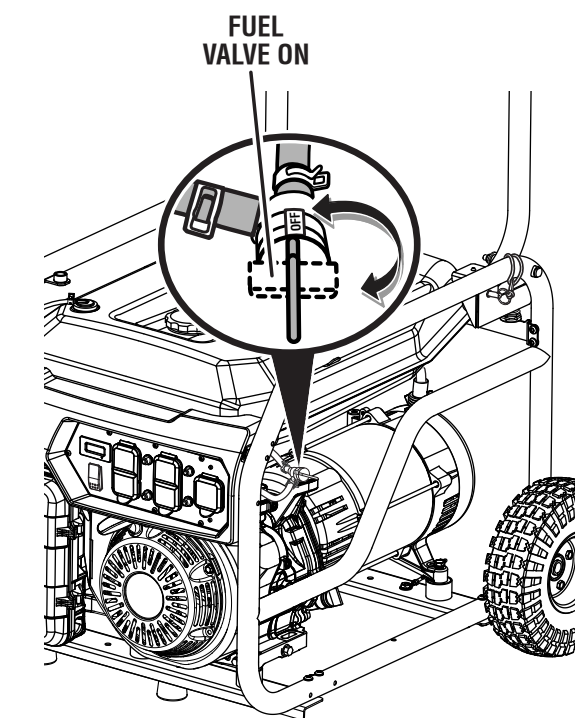

## STOPPING THE UNIT

### 1 Press and hold the engine stop switch in the OFF position until the engine has come to a complete stop (see page 14).

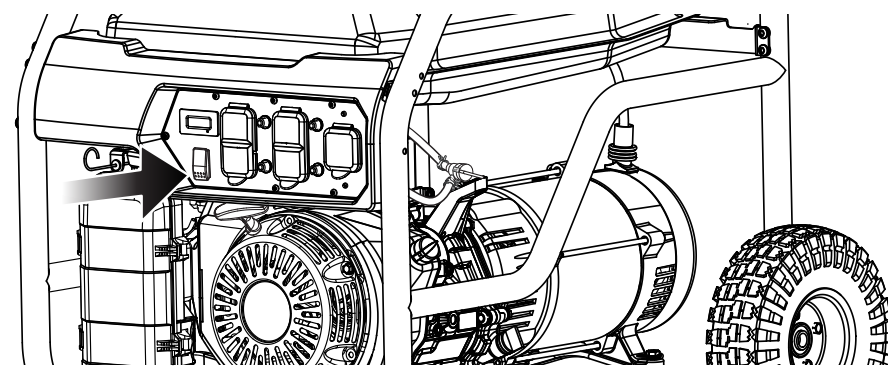

### 3 Pull choke out to START position (see page 14).

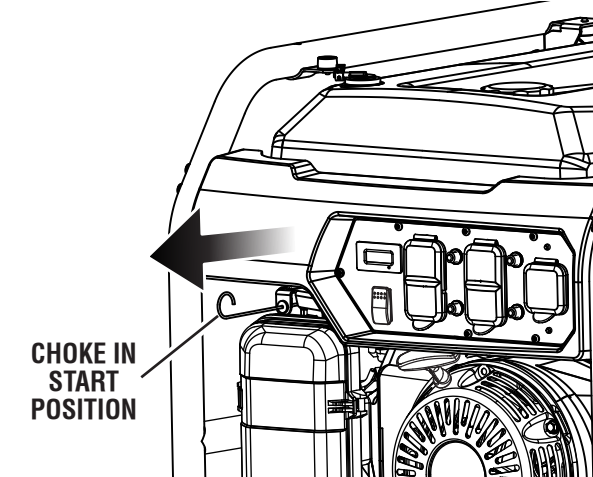

### 4 Pull the recoil starting grip until the engine runs (see page 14).

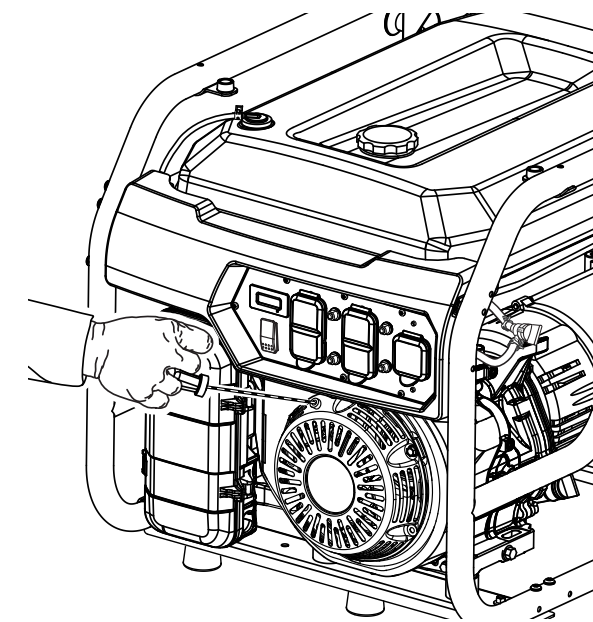

### 5 Allow engine to run for 15-30 seconds, then push choke in to RUN position (see page 14).

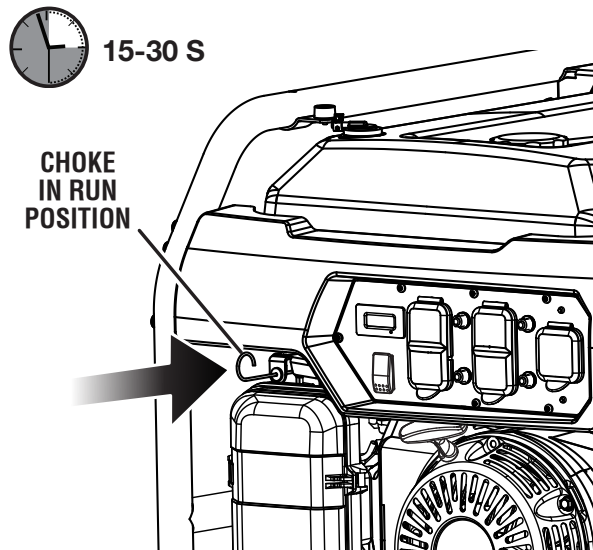

## USING THE GENERATOR

### 1 Connect devices to be powered by generator by following the steps below (see pages 8-9).

- Make sure the generator can supply enough continuous (running) and surge (starting) watts for the items you will power at the same time. See page 9 for how to calculate total amount of power needed.
- Start the generator with nothing connected.
- Plug in and turn on the first load, preferably the largest load you have.
- Permit the generator output to stabilize (engine runs smoothly and attached device operates properly).
- Plug in and turn on the next load.
- Again, permit the generator to stabilize.
- Repeat previous two steps for each additional load.

**IMPORTANT:** Never add more loads than the generator capacity. Take special care to consider surge loads in generator capacity. (See pages 8-9.)

## STORING THE UNIT

### 1 When preparing to store the generator, allow the unit to cool for 30 minutes, then follow the guidelines listed on page 17.

## TROUBLESHOOTING

PROBLEM	POSSIBLE CAUSE	SOLUTION
Engine will not start.	No fuel. Stale gasoline or water in gasoline. Lubricant level is low.  Fuel valve is OFF. Spark plug faulty, fouled, or improperly gapped. Choke is in RUN position. Engine stored without treating or draining gasoline, or refueled with bad gasoline. Dirty fuel filter.	Fill fuel tank. Drain entire system and refill with fresh fuel. Check engine lubricant level and fill, if necessary. Turn fuel valve ON. Replace spark plug.  Move choke to START position. Drain fuel and carburetor. Refuel with fresh gasoline. Replace fuel filter or contact a qualified service center.
Engine hard to start.	Water in gasoline. Weak spark at spark plug.	Drain entire system and refill with fresh fuel. Replace spark plug or contact a qualified service center.
Engine lacks power.	Dirty air filter.  Engine stored without treating or draining gasoline, or refueled with bad gasoline.	Check air filter element. Clean or replace as needed. Drain fuel and carburetor. Refuel with fresh gasoline. If problem continues, contact a qualified service center.
AC receptacle does not work.	Circuit breaker is tripped. GFCI is tripped. Item plugged in is defective.	Reset the AC circuit breaker. Reset the GFCI. Try a different item.
Generator makes a "spark knock" or "pinging" noise.	An occasional light "knocking" or "pinging" under heavy load is not a cause for concern. However, if the knocking or pinging occurs under normal load at a steady engine speed, the problem may be with the brand of gasoline being used.	Switch to a different brand of gasoline, making sure that the octane rating is 86 or higher. If problem continues, contact a qualified service center.

If problem persists after trying the above solutions, contact customer service or a qualified service center for assistance.

### NOTICE:

As the equipment owner, you are responsible for the performance of the required maintenance listed in the *Maintenance* section. It is recommended that you retain all receipts covering maintenance on your equipment. Neglecting or failing to perform the required maintenance may increase emissions, decrease fuel efficiency, degrade performance, cause irreversible engine damage and/or void your warranty.

**Make the most of your purchase! Go to [www.ryobitools.com](http://www.ryobitools.com) and register your new tool online. For questions about operating or maintaining your product, please call 1-800-860-4050.**

**RYOBI**