

# RY905500E QUICK REFERENCE GUIDE

## ⚠ WARNING:

This Quick Reference Guide is not a substitute for reading the operator's manual. To reduce the risk of injury or death, user must read and understand operator's manual before using this product. All page references refer to the operator's manual.

## IMPORTANT!

### ⚠ WARNING:

Do not connect to a building's electrical system unless the generator and transfer switch have been properly installed and the electrical output has been verified by a qualified electrician. The connection must isolate the generator power from utility power and must comply with all applicable laws and electrical codes.

### ⚠ DANGER

Using a generator indoors **CAN KILL YOU IN MINUTES**. Generator exhaust contains carbon monoxide. This is a poison you cannot see or smell.



NEVER use inside a home or garage, EVEN IF doors and windows are open.



Only use OUTSIDE and far away from windows, doors, and vents.

## TOOLS NEEDED

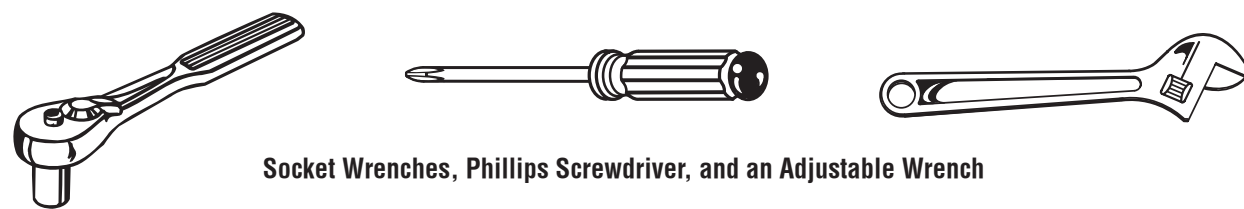

Socket Wrenches, Phillips Screwdriver, and an Adjustable Wrench

## FIRST TIME ASSEMBLY

1 Install the feet (see page 11).

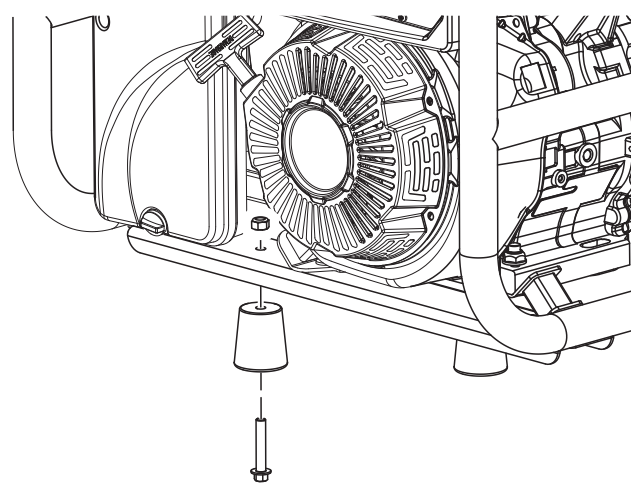

2 Install the wheels (see page 12).

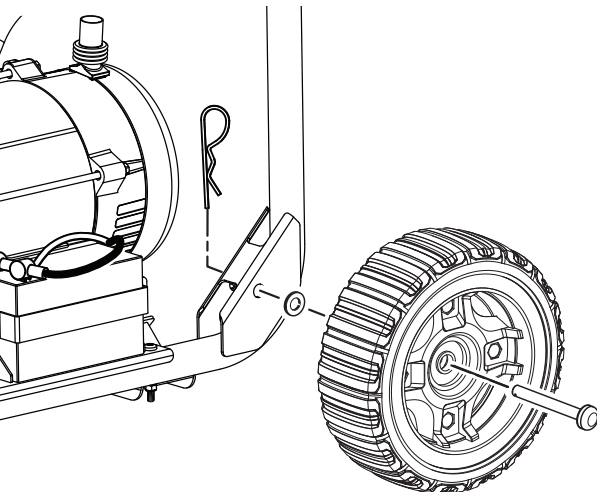

3 Connect the battery (see page 12).

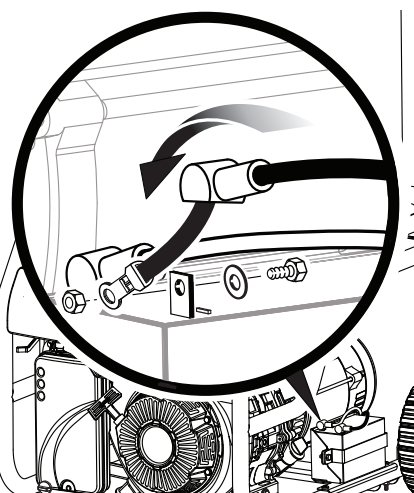

4 Raise the handle (see page 13).

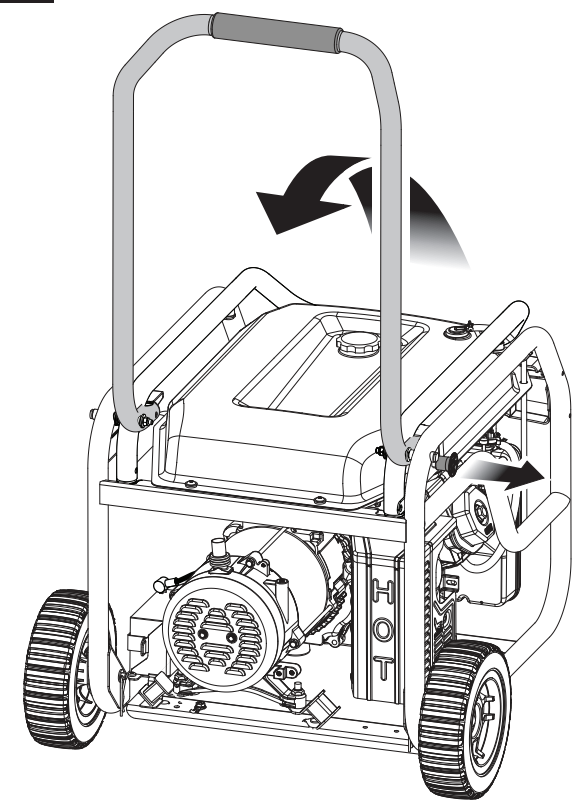

5 Add entire bottle of lubricant provided to the generator (see page 14).

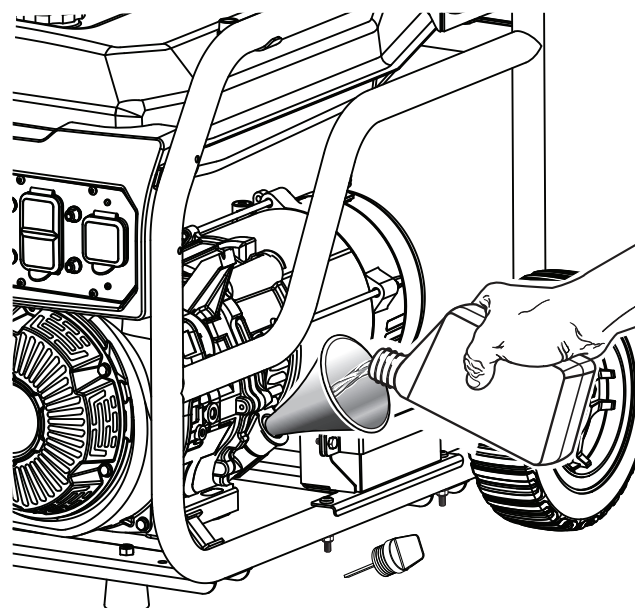

Set unit on flat surface so engine is level. Remove dipstick, wipe clean, put back in hole (but don't screw in) and check lubricant level.

## STARTING THE UNIT

1 Add fuel (see page 14).

### NOTICE:

Do not use E15 or E85 fuel in this product. It is a violation of federal law and will damage the unit and void your warranty. Only use unleaded gasoline containing up to 10% ethanol.

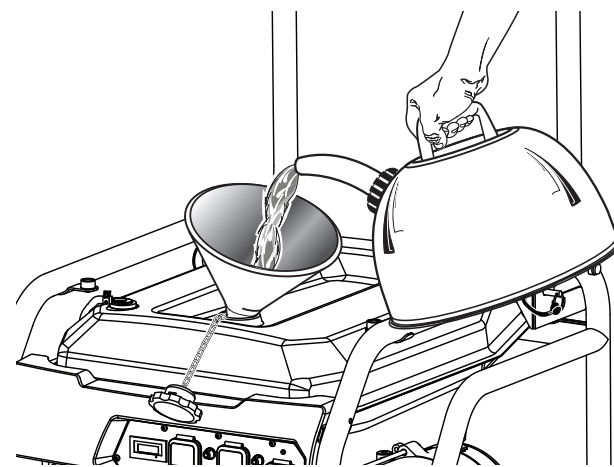

This is a 4-cycle engine. Do not mix fuel and lubricant together.

Mix fuel stabilizer with gasoline according to manufacturer's directions prior to filling the tank.

2 Verify the run switch is in the ON position, then place the engine switch/fuel valve/choke lever in the START position (see page 15).

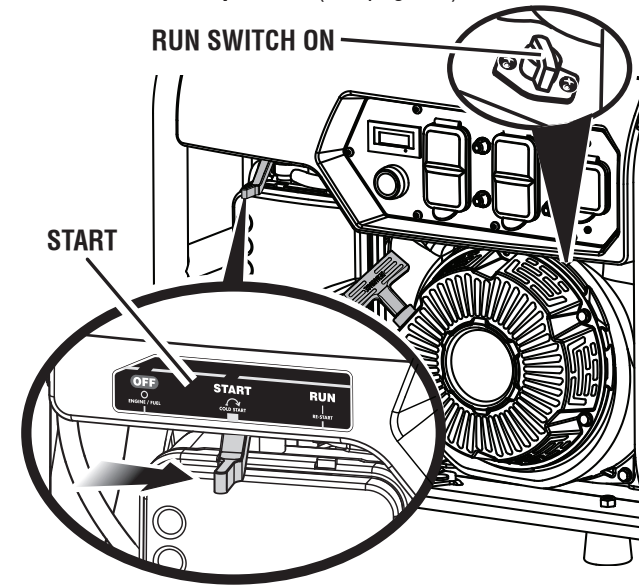

3 Press the start button to start the engine. Engine can also be started by pulling the recoil starting grip until the engine runs. (See page 15)

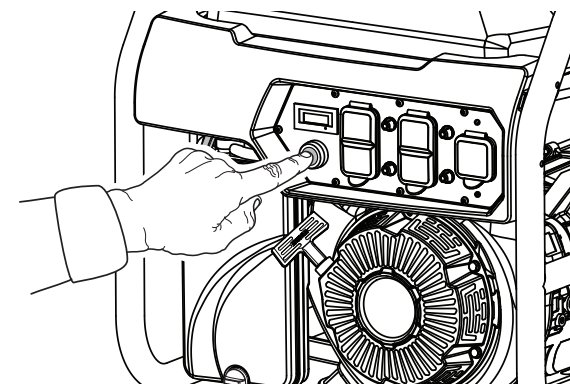

OR PULL RECOIL STARTER TO START

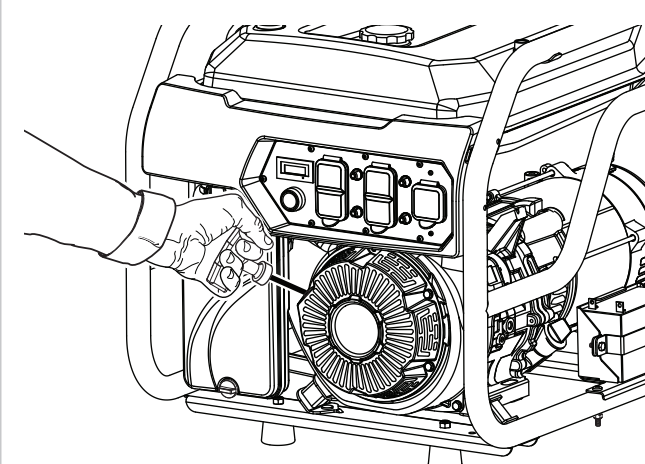

4 Allow engine to run for 15–30 seconds, then move the engine switch/fuel valve/choke lever to the RUN position (see page 15).

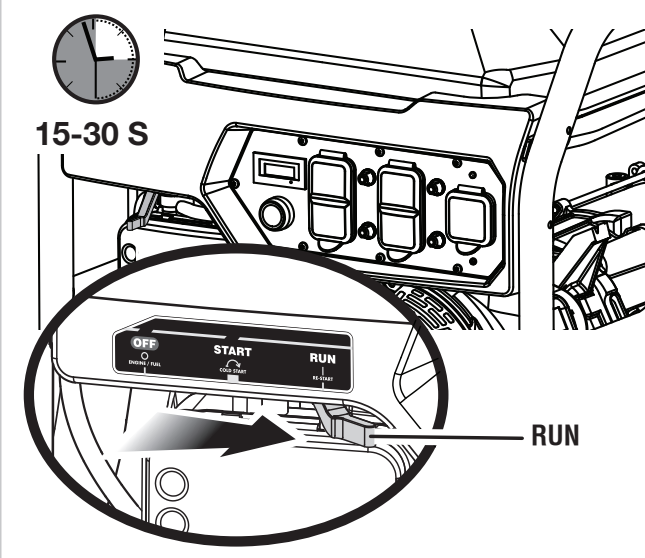

## STOPPING THE UNIT

1 Place the engine switch/fuel valve/choke lever in the OFF position (see page 15).

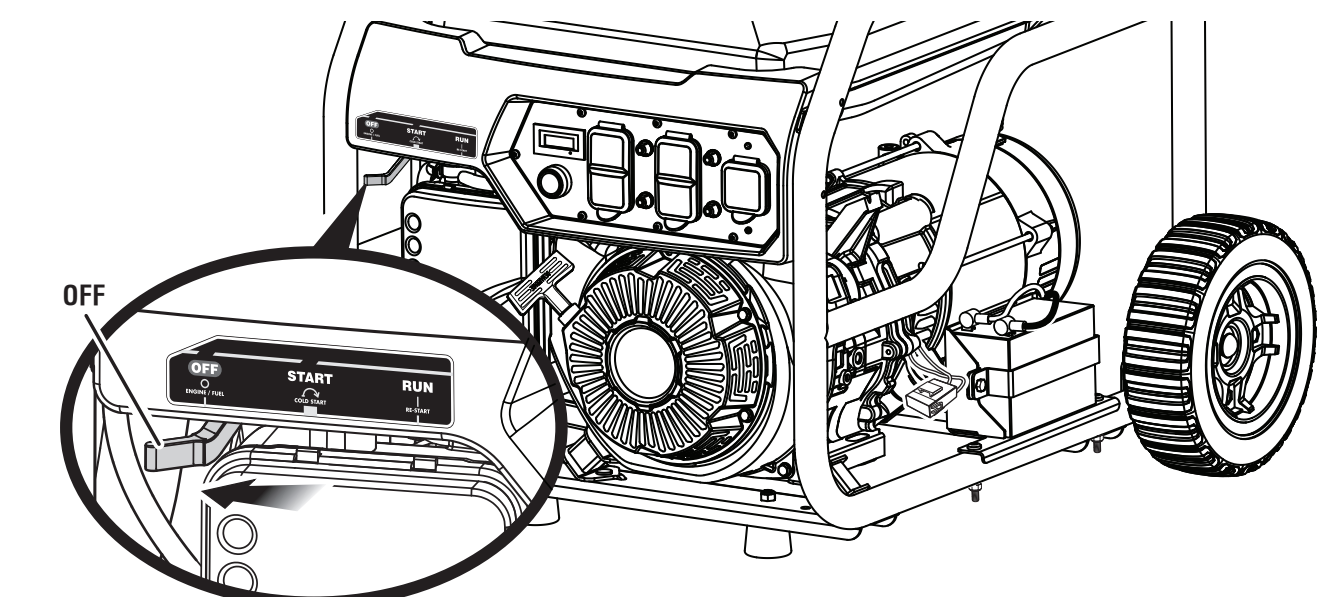

## USING THE GENERATOR

1 Connect devices to be powered by generator by following the steps below (see pages 8-9).

- Make sure the generator can supply enough continuous (running) and surge (starting) watts for the items you will power at the same time. See page 9 for how to calculate total amount of power needed.
- Start the generator with nothing connected.
- Plug in and turn on the first load, preferably the largest load you have.
- Permit the generator output to stabilize (engine runs smoothly and attached device operates properly).
- Plug in and turn on the next load.
- Again, permit the generator to stabilize.
- Repeat previous two steps for each additional load.

**IMPORTANT:** Never add more loads than the generator capacity. Take special care to consider surge loads in generator capacity. (See pages 8-9.)

## STORING THE UNIT

1 When preparing to store the generator, allow the unit to cool completely, then follow the guidelines listed on page 19.

## TROUBLESHOOTING

PROBLEM	POSSIBLE CAUSE	SOLUTION
Engine will not start.	Run switch is in the OFF position. No fuel. Stale gasoline or water in gasoline. Lubricant level is low.	Turn run switch ON. Fill fuel tank. Drain entire system and refill with fresh fuel. Engine is equipped with Low Oil Shutoff. If engine lubricant level is low, it must be filled before unit will start. Check engine lubricant level and fill, if necessary.
	Spark plug faulty, fouled, or improperly gapped. Engine switch/fuel valve/choke lever is in OFF or RUN position. Engine stored without treating or draining gasoline, or refueled with bad gasoline. Dirty fuel filter.	Replace spark plug. Move engine switch/fuel valve/choke lever to START position. Drain fuel and carburetor. Refuel with fresh gasoline. Replace fuel filter or contact a qualified service center.
Engine hard to start.	Water in gasoline. Weak spark at spark plug.	Drain entire system and refill with fresh fuel. Replace spark plug or contact a qualified service center.
Engine lacks power.	Dirty air filter. Engine stored without treating or draining gasoline, or refueled with bad gasoline.	Check air filter element. Clean or replace as needed. Drain fuel and carburetor. Refuel with fresh gasoline.
Electric start feature not working.	Engine switch/fuel valve/choke lever is in OFF position. Battery wires are disconnected. Battery is not charged. Engine battery charge circuit fuse is blown.	Move engine switch/fuel valve/choke lever to START or RUN position. Connect the battery wires. Charge the battery. Replace the engine battery charge circuit fuse.
AC receptacle does not work.	Circuit breaker is tripped. GFCI is tripped. Item plugged in is defective.	Reset the AC circuit breaker. Reset the GFCI. Try a different item.
Generator makes a "spark knock" or "pinging" noise.	An occasional light "knocking" or "pinging" under heavy load is not a cause for concern. However, if the knocking or pinging occurs under normal load at a steady engine speed, the problem may be with the brand of gasoline being used.	Switch to a different brand of gasoline, making sure that the octane rating is 86 or higher. If problem continues, contact a qualified service center.

If problem persists after trying the above solutions, contact customer service or a qualified service center for assistance.

### NOTICE:

As the equipment owner, you are responsible for the performance of the required maintenance listed in the Maintenance section. It is recommended that you retain all receipts covering maintenance on your equipment. Neglecting or failing to perform the required maintenance may increase emissions, decrease fuel efficiency, degrade performance, cause irreversible engine damage and/or void your warranty.

**Make the most of your purchase! Go to [www.ryobitools.com](http://www.ryobitools.com) and register your new tool online. For questions about operating or maintaining your product, please call 1-800-860-4050.**

**RYOBI**