

⚠ WARNING:

This Quick Reference Guide is not a substitute for reading the operator's manual. To reduce the risk of injury or death, user must read and understand operator's manual before using this product. All page references refer to the operator's manual.

FIRST TIME ASSEMBLY

1 Install the handle (see page 7).

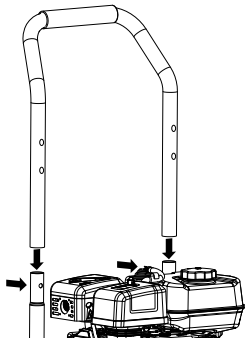

2 Install the storage panel and trigger handle holder (see page 7).

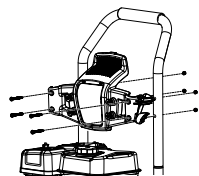

3 Connect the spray wand to the trigger handle (see page 7).

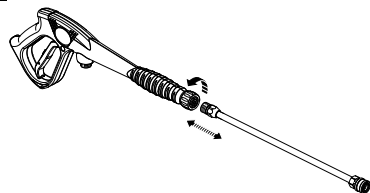

4 Connect the high pressure hose to the trigger handle (see page 8).

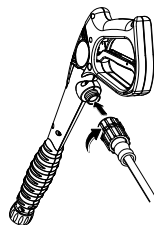

5 Connect the high pressure hose to the pump (see page 8).

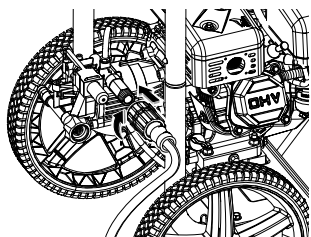

Completely uncoil and straighten high pressure hose to prevent kinks.

6 Connect your garden hose to the pressure washer (see page 8).

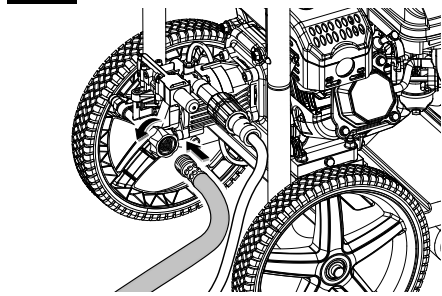

Completely uncoil garden hose or remove completely from reel to prevent kinks.

Turn water faucet on fully.

Make sure there are no leaks.

With no nozzle installed, squeeze the trigger to relieve air pressure. Hold the trigger until a steady stream of water appears.

7 Pour all but 2 oz. of the provided lubricant into the engine through the oil fill hole. Check and add additional lubricant as needed until the level reaches the upper portion of the hatched area on the dipstick. Do not overfill. (See page 9).

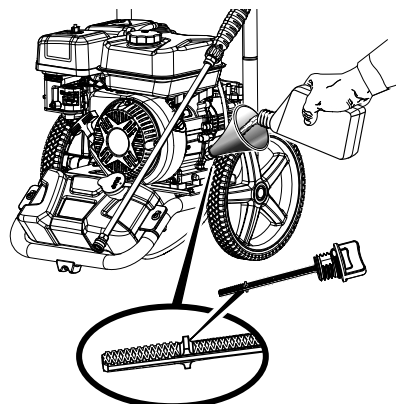

Turn the fuel valve to OFF before adding lubricant.

Set unit on flat surface so engine is level. Remove dipstick, wipe clean, put back in hole (but don't screw in) and check lubricant level.

STARTING THE UNIT (COLD START)

1 Add fuel (see page 10).

NOTICE:

Do not use E15 or E85 fuel in this product. It is a violation of federal law and will damage the unit and void your warranty. Only use unleaded gasoline containing up to 10% ethanol.

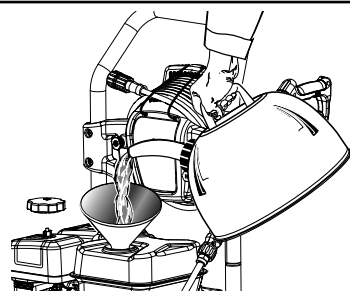

This is a 4-cycle engine. Do not mix fuel and lubricant together.

Mix fuel stabilizer with gasoline according to manufacturer's directions prior to filling the tank.

2 Move the fuel valve to OPEN (see page 10).

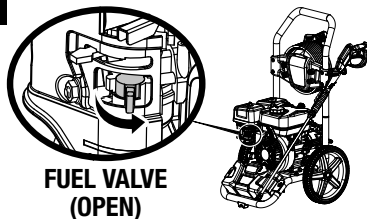

3 Put on/off switch in ON position (see page 10).

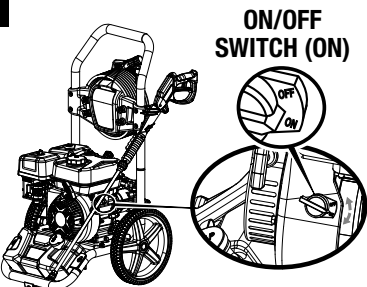

4 Move choke lever to START position. (see page 10).

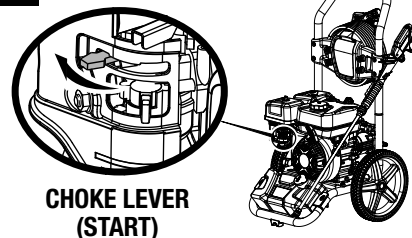

5 Pull starter grip and rope to start (see page 10).

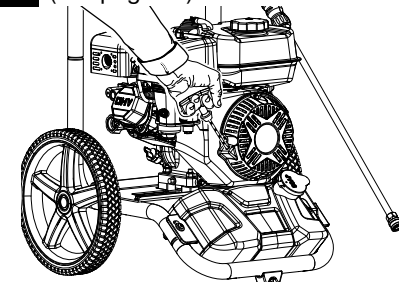

6 Allow engine to run for several seconds, then move choke lever to RUN position (see page 10).

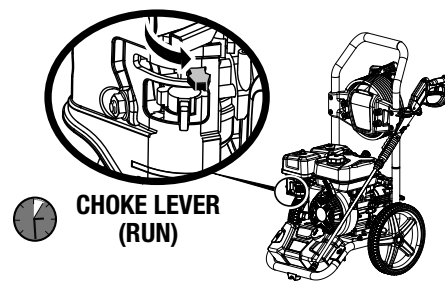

RESTARTING THE UNIT (HOT RESTART)

1 Pull starter grip and rope to start (see page 10).

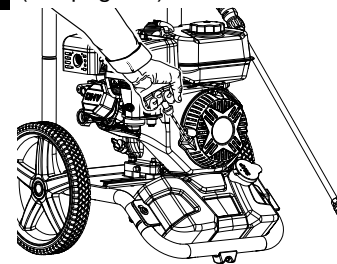

If the engine does not start:

- check for enough fuel;
- may need to adjust choke position;
- try starting again.

There may be residual water in the pump and/or lubricant in the engine due to performance testing.

USING DETERGENT

1 Pour pressure washer detergent in soap tank (see page 12).

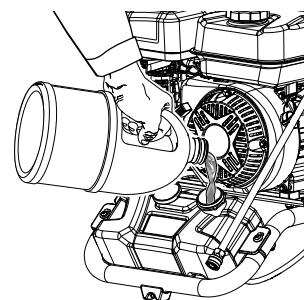

2 Install blue or black soap nozzle (see page 12).

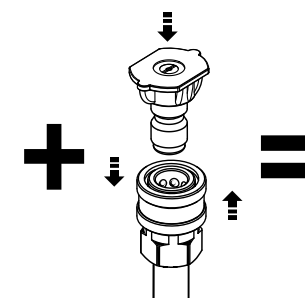

3 Squeeze trigger and wait approx. 5 seconds for detergent (see page 12).

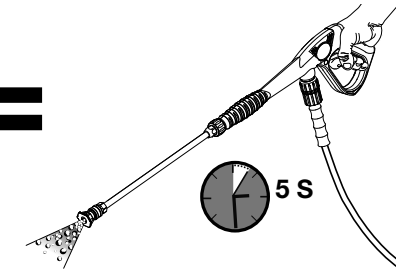

Use of soap nozzle will activate soap injector at a 20:1 dilution ratio. **WARNING!** Never use bleach or solvent-based detergent.

- Will damage your pump
- Will void your warranty
- Will damage plants/shrubs

NOZZLE SELECTION GUIDE

Use the chart below to determine the correct nozzle for your job.

| 2 nd Story Nozzle | 25° | 40° | SOAP | |
|------------------------------|-----------------------|-----|---|--|
| | | | HIGH PRESSURE (NO SOAP WHEN USING THESE NOZZLES) | LOW PRESSURE (FOR SOAP OR GENTLE RINSE) |
| ABRASIVE | 2 nd Story | 25° | 40° | Blue or Black Soap Nozzle |
| Concrete, Brick, Masonry | ✓ | ✓ | ✓ | ✓ |
| Siding, Gutters, House | ✓ | ✓ | ✓ | ✓ |
| Fencing, Deck, Patio | ✓ | ✓ | ✓ | ✓ |
| Lawn Equipment, Boat, RV | ✓ | ✓ | ✓ | ✓ |

✓ Recommended Nozzle ✓ Use With Caution for Certain Applications

BEFORE STORING THE UNIT

1 Always add Pump Protector to the unit after each use and before storing. This will significantly improve pump life. (See page 13) Pump Protector is available from your local retailer. For further assistance, call customer service at 1-800-525-2579. To add, follow the instructions provided by the Pump Protector manufacturer.



Make the most of your purchase! Go to www.ryobitools.com and register your new tool online. For questions about operating or maintaining your product please call, 1-800-525-2579.

DO NOT OVERTILT THE UNIT!

