

REPAIR SHEET

BRAND RYOBI		DESCRIPTION 40 Volt Snow Blower
MODEL NO. RY40806 RY40806VNM	MFG. NO. 107836001 107836101	

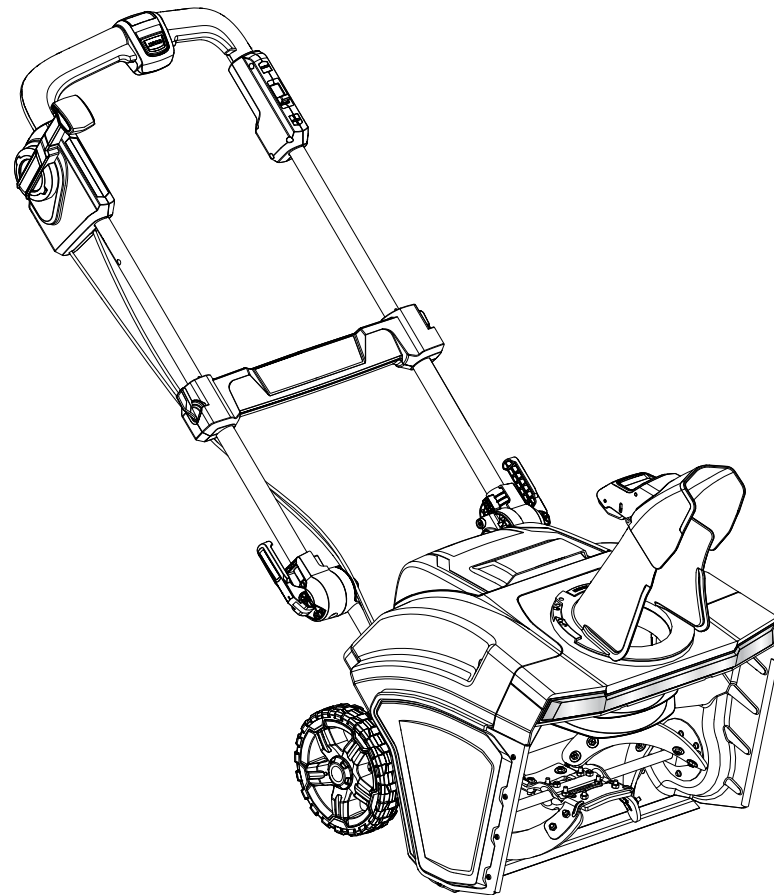

TTI OUTDOOR POWER EQUIPMENT, INC.

P.O. Box 1288, Anderson, SC 29622 ■ 1-800-525-2579 ■ www.ryobitools.com

4-1-24 (Rev:04)

The model number and manufacturing location will be found on a label attached to the product. Always mention this information in all communications regarding this product and when ordering parts.

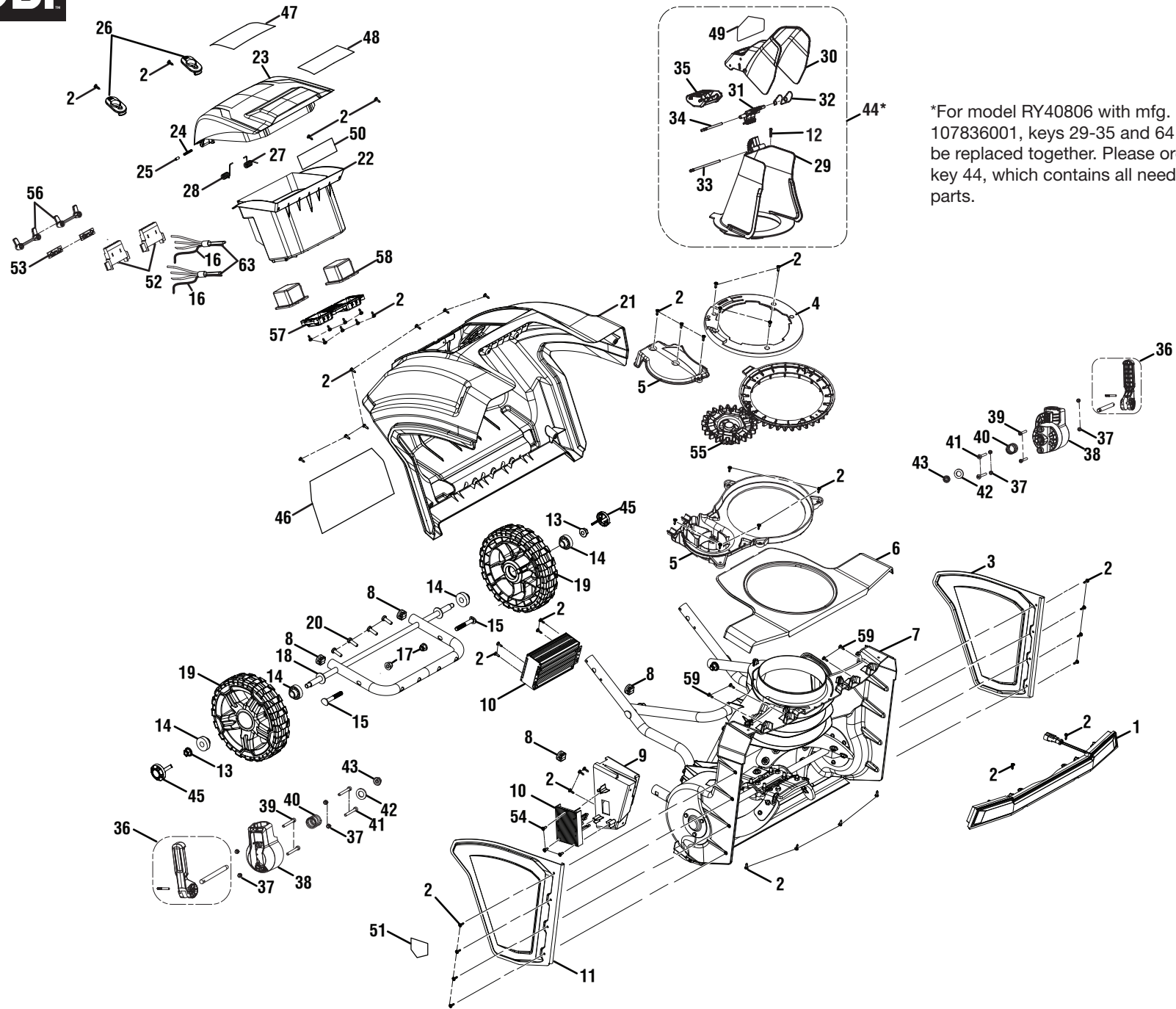

*For model RY40806 with mfg. no. 107836001, keys 29-35 and 64 must be replaced together. Please order key 44, which contains all needed parts.



RY40806/RY40806VNM

PARTS LIST – FIGURE A

KEY NO.	PART NO.	DESCRIPTION	QTY.
1	315043001	LED Light Assembly	1
2	660608001	Screw (M4 x 12 mm, T20 Torx Soc. Hd.)	52
3	658280001	Left Side Cover	1
4	537736001	Chute Rotation Bezel	1
5	315817001	Chute Rotation Assembly	1
6	537727001	Top Housing Cover	1
7	See Figure C	Auger Housing Assembly	1
8	52933002	Plug	4
9	315820001	Mount Assembly (See Fig. C, Inc. Key No. 17)	1
10	280400018	Battery Controller & Brushless Motor Controller	1
11	315805001	Right Side Cover Assembly (Inc. Key No. 51)	1
12*	660208050	Screw (M4 x 20 mm, Phillips -Pan Hd., RY40806VNM)	1
13	662082001	Lock Nut (3/8-16 in.)	2
14	538520001	Wheel Spacer	4
15	662339001	Bolt (M8 x 60 mm, Pan Hd.)	2
16	291547004	Wire Assembly	2
17	678774012	Flange Lock Nut (M8 x 1.25 mm)	2
18	314993001	Axle and Lower Frame Assembly	1
19	313618001	Wheel	2
20	664004003	Screw (1/4-15, T30 Torx Pan Hd.)	4
21	315804001	Rear Cover Assembly (Inc. Key No. 46, RY40806)	1
	317940001	Rear Cover Assembly (Inc. Key No. 46, RY40806VNM)	1
22	315812001	Battery Box Assembly (Inc. Key No. 50)	1
23	315807001	Battery Cover Assembly (Inc. Key Nos. 47-48)	1
24	679073001	Compression Spring	1
25	621628001	Axle	1
26	537718001	End Cap	2
27	698023001	Torsion Spring (RH)	1
28	698023002	Torsion Spring (LH)	1
29*	537741001	Upper Chute	1
30*	537740001	Chute Deflector	1
31*	541032001	Latch	1
32*	697882002	Chute Deflector Spring	1

KEY NO.	PART NO.	DESCRIPTION	QTY.
33*	673981001	Pin (Deflector)	1
34*	673990001	Pin (Latch)	1
35*	537743001	Button	1
36	315816001	Cam Latch Assembly	2
37	670974003	Lock Nut (M5)	8
38	315808001	Knuckle Assembly	1
39	660347003	Cap Screw (M5 x 45 mm, T25 Torx Soc Hd.)	4
40	696920001	Compression Spring	2
41	662466001	Screw (M5 x 35 mm, T25 Torx Pan Hd.)	4
42	678889003	Washer (ID12.5 x OD24 x 2t)	2
43	690689001	Flange Hex Nut (M8)	2
44	315044001	Chute Deflector Assembly w/Label (Inc. Key Nos. 29-35 & 64)	1
45	535063001	Wheel Hub	2
46	941588393	Data/Warning Icons Label (RY40806)	1
	941588623	Data/Warning Icons Label (RY40806VNM)	1
47	941588394	Battery Notice Label	1
48	941588395	Logo Label (Battery Cover)	1
49	941588400	Chute Warning Icons Label	1
50	941588401	Recommended Battery Usage Label	1
51	941641001	No Hands/Feet Danger Label	1
52	525692001	Contact Holder	2
53	525651001	Battery Cover Connector	2
54	661189003	Screw (M4 x 18 mm, T20 Torx Hd.)	3
55	315809001	Chute Gear Assembly	1
56	513211003	Hold-Down Tab	2
57	537745001	Spring Retainer	1
58	537742001	Battery Ejector Post	2
59	660203001	Screw (M3 x 8 mm, Pan Hd.)	4
	Not Shown:		
	995000844	Operator's Manual	

*For RY40806 with mfg. no. 107836001, keys 29-35 and 64 must be replaced together. Please order key 44, which contains all needed parts.

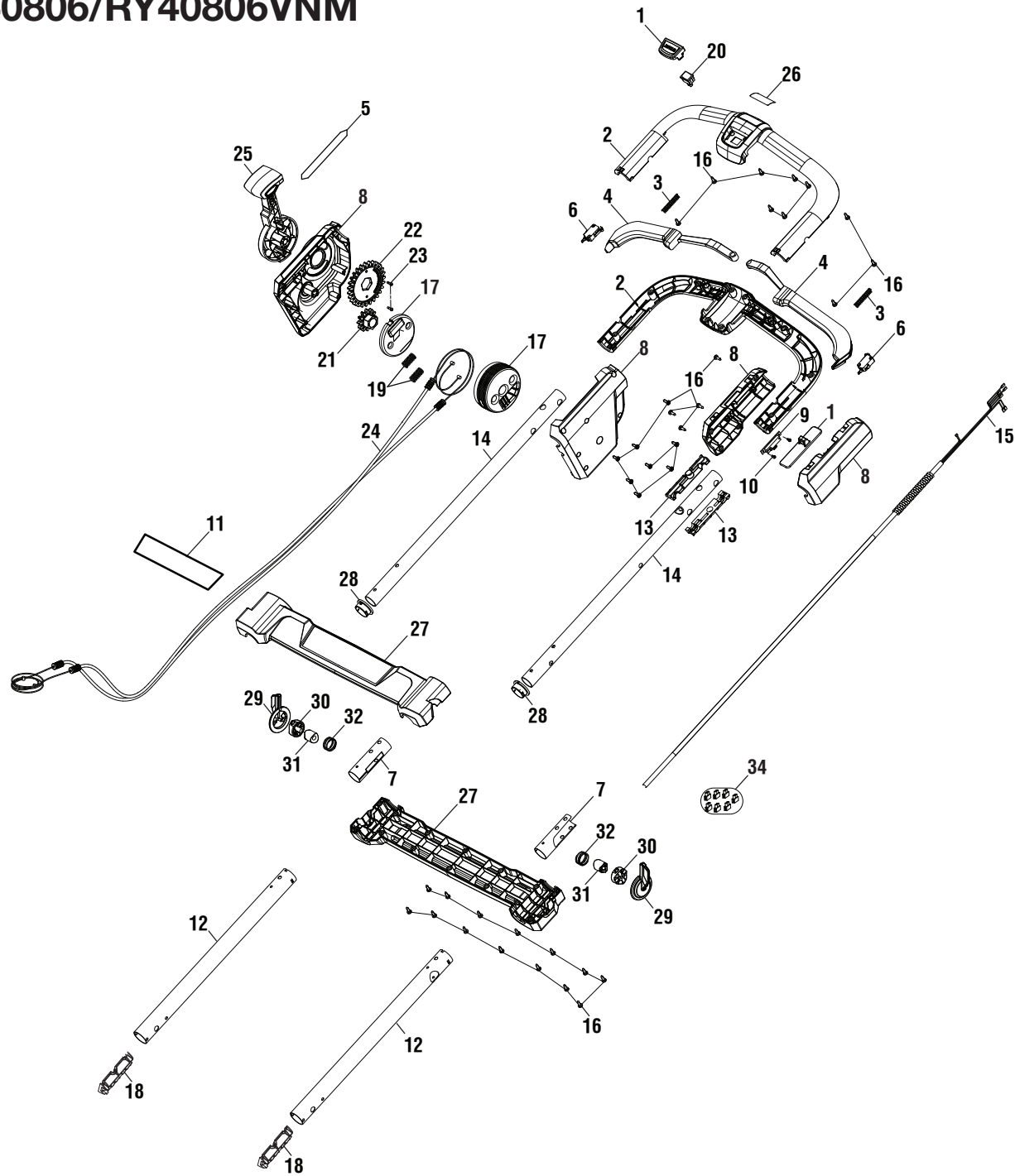



RY40806/RY40806VNM

PARTS LIST – FIGURE B

KEY NO.	PART NO.	DESCRIPTION	QTY.
1	315819001	Switch Button Assembly	1
2	315815001	Handle Cover Assembly (Inc. Key No. 26)	1
3	696926001	Compression Spring	2
4	315818001	Trigger Assembly	1
5	941588390	Chute Direction Label	1
6	760551003	Switch	2
7	541030001	Bushing	2
8	315811001	Chute Adjust & Speed Control Assembly	1
9	270109001	Variable Switch	1
10	660203073	Screw (M3 x 6 mm, Pan Hd.)	2
11	941588392	Logo Label (Crossbar)	1
12	697789001	Lower Tube	2
13	538598001	Upper Cable Gland	2
14	697788001	Upper Handle Tube	2
15	292106002	Wire Assembly	1
16	660608001	Screw (M4 x 12 mm, T20 Torx Soc. Hd.)	36
17	315810001	Cable Drum Assembly	1

KEY NO.	PART NO.	DESCRIPTION	QTY.
18	539052001	Lower Cable Bushing	2
19	697796001	Spring	2
20	760653001	Center Switch	1
21	614251001	Upper Drum Gear	1
22	614250001	Lever Gear	1
23	660187002	Screw (M3 x 22 mm, T10 Torx Pan Hd.)	2
24	292112001	Control Cable Assembly	1
25	537833001	Chute Rotation Handle	1
26	941588391	Starting Instructions Label	1
27	315814001	Cross Bar Assembly (Inc. Key No. 11)	1
28	529327001	Straight Tube Bushing	2
29	536916003	Handle Latch	2
30	536919003	Disc Holder	2
31	565045001	Compression Disc (45A)	2
32	697483001	Compression Spring	2

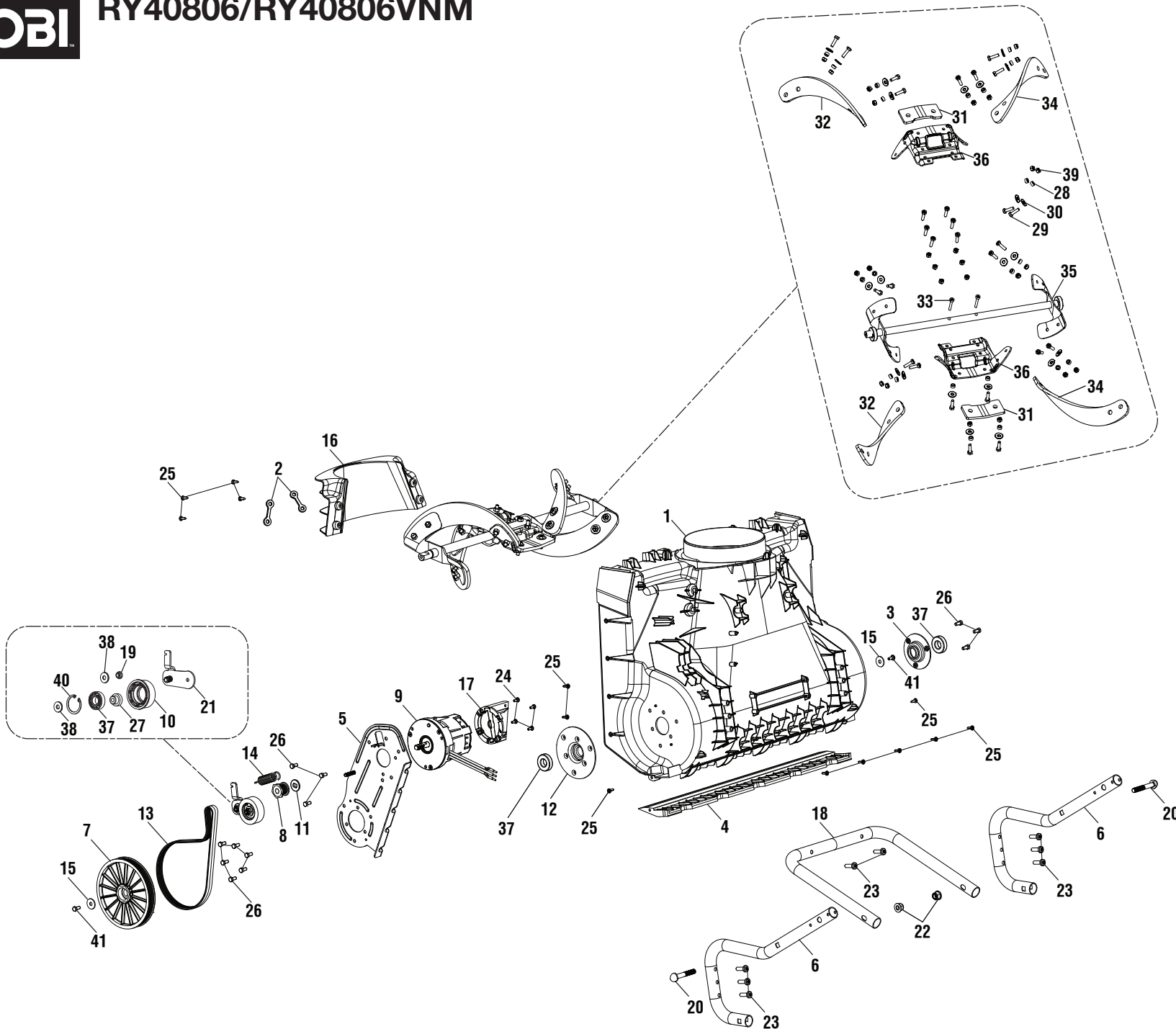



RY40806/RV40806VNM

PARTS LIST – FIGURE C

KEY NO.	PART NO.	DESCRIPTION	QTY.
1	537723001	Lower Housing	1
2	529299001	Terminal Block Holder	2
3	658276001	Bearing Retainer	1
4	539777001	Scraper Blade	1
5	658275001	Motor Mounting Plate	1
6	697786001	Housing Mount Tube	2
7	537737001	Auger Pulley	1
8	311275002	Motor Pulley	1
9	742515002	Motor	1
10	537834001	Idler Pulley	1
11	614164001	Spacer	1
12	658396001	Bearing Retainer Plate	1
13	563939002	V-Belt	1
14	697873001	Belt Tensioner Spring	1
15	636191001	Flat Washer (ID6.6 x OD20 x 1.6t)	2
16	538542001	Lower Chute Neck	1
17	315820001	Mount Assembly (See Figure A, Inc. Key No. 9)	1
18	658575001	Bracing Bar	1
19	614166001	Flange Washer	1
20	T662339001	Bolt (M8 x 60 mm, Pan Hd.)	2
21	658395001	Idler Bracket	1

KEY NO.	PART NO.	DESCRIPTION	QTY.
22	678774012	Flange Lock Nut (M8 x 1.25 mm)	2
23	664004003	Screw (1/4-15 x 22 mm, T30 Torx Pan Hd.)	8
24	661861004	Screw (M4 x 9.5 mm, Pan Hd.)	4
25	660608001	Screw (M4 x 12 mm, T20 Torx Soc. Hd.)	13
26	660927008	Bolt (M5 x 12 mm, Hex Soc. Hd.)	12
27	614165001	Spacer (Idler Bracket)	1
28	697795001	Auger Paddle Spacer	20
29	661618002	Bolt (M6 x 16 mm, Hex Soc. Hd.)	24
30	680335079	Washer (OD18 x ID6.6 x 1.5t)	24
31	565320001	Auger Paddle (Center)	2
32	565321001	Auger Paddle (Drive Side)	2
33	660613004	Screw (M5 x 30 mm, T25 Torx Pan Hd.)	2
34	565176001	Auger Paddle (Long Side)	2
35	315336001	Flange and Shaft Assembly	1
36	658279001	Center Bracket	1
37	680071012	Ball Bearing (6002 2RS)	3
38	680491003	Washer (OD18.8 x ID7 x 2t)	2
39	678460001	Lock Nut (M6)	26
40	636327001	C-Ring	1
41	660697003	Bolt (M6 x 12 mm, T27 Torx Hd.)	2

