

# REPAIR SHEET

BRAND		DESCRIPTION
<b>RYOBI</b>		
MODEL NO.	MFG. NO.	<b>38cc Chain Saws</b>
<b>RY3714</b>	<b>090382013</b>	
<b>RY3714VNM</b>	<b>095382013, 095382028</b>	
<b>RY3716</b>	<b>090382012</b>	
<b>RY3716VNM</b>	<b>095382012, 095382027</b>	

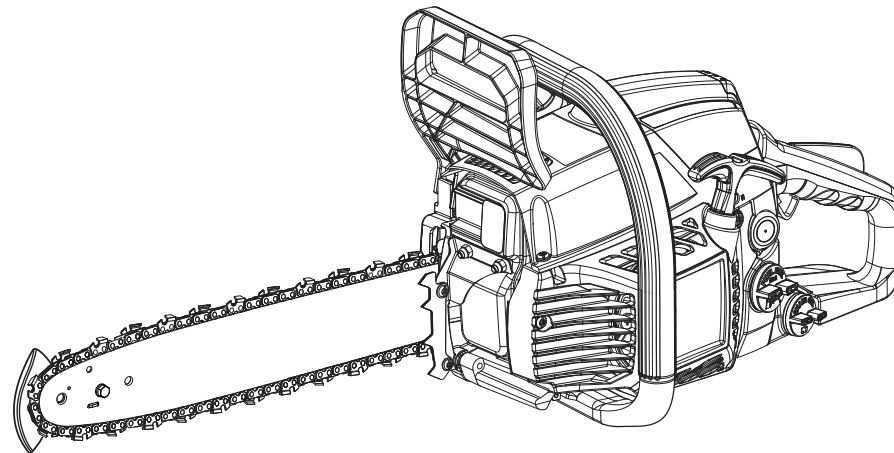

**TTI OUTDOOR POWER EQUIPMENT, INC.**

P.O. Box 1288, Anderson, SC 29622 ■ 1-800-525-2579 ■ [www.ryobitools.com](http://www.ryobitools.com)

12-7-21 (Rev:03)

*The model number and manufacturing location will be found on a label attached to the product. Always mention this information in all communications regarding this product and when ordering parts.*

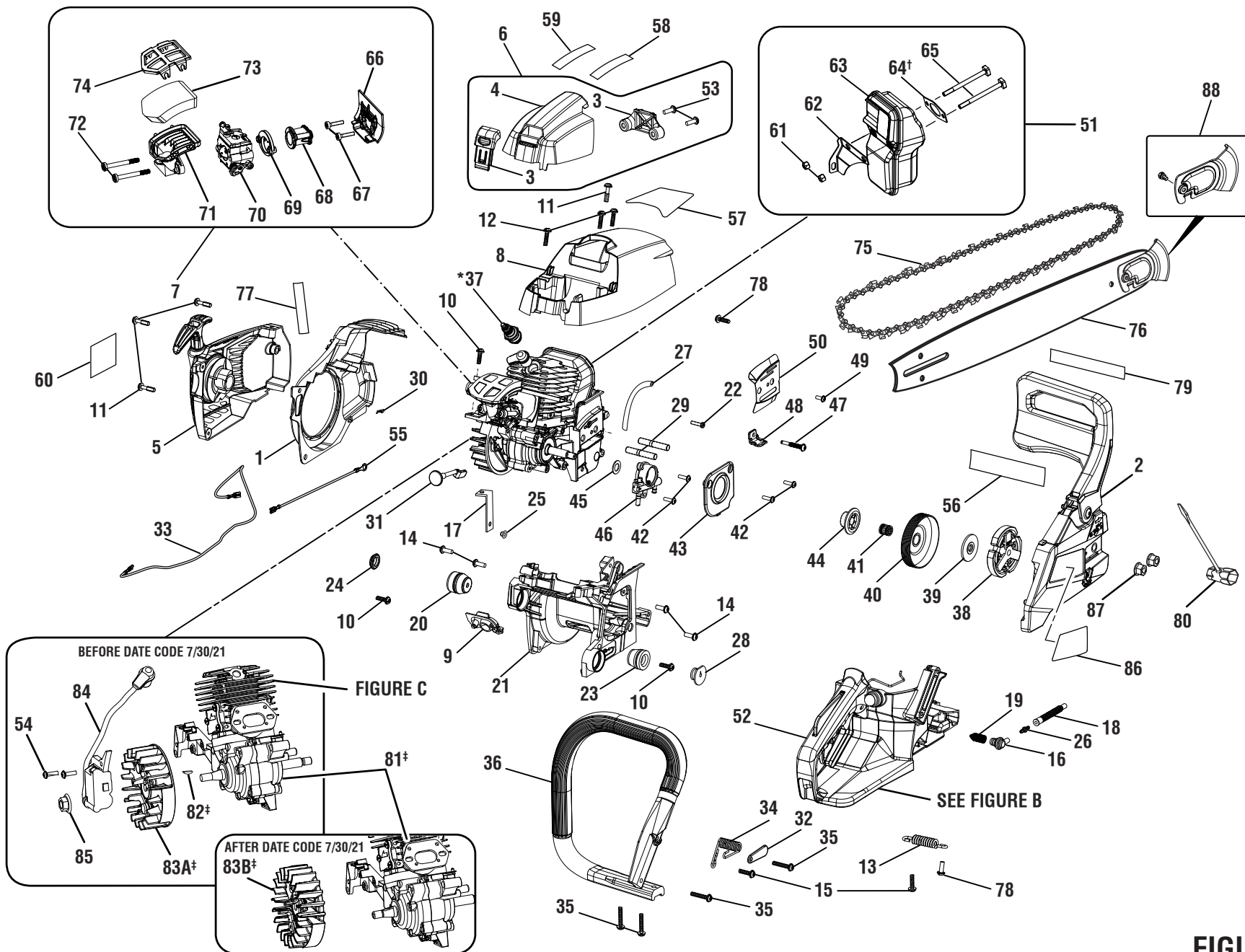

**FIGURE A**



# RY3714/RY3714VNM/RY3716/RY3716VNM

## PARTS LIST – FIGURE A

KEY NO.	PART NO.	DESCRIPTION	QTY.
1	533483001	Cylinder Baffle	1
2	313866003	Clutch Cover Assembly (Inc. Key Nos. 56 & 79, RY3714)	1
	313866002	Clutch Cover Assembly (Inc. Key Nos. 56 & 79, RY3716)	1
3	314046001	Carburetor Cover Latch and Bracket Assembly	1
4	532595001	Carburetor Cover Housing	1
5	313867006	Starter Housing Assembly (Inc. Key Nos. 60 & 77, RY3714)	1
	313867005	Starter Housing Assembly (Inc. Key Nos. 60 & 77, RY3716)	1
6	313868001	Carburetor Cover Assembly (Inc. Key Nos. 58-59)	1
7	311457003	Intake Assembly	1
8	313869001	Cylinder Housing Assembly (Inc. Key No. 57)	1
9	518417001	Grommet	1
10	660918003	Screw (M5 x 16 mm, T25 Torx Pan Hd.)	3
11	660637001	Screw (M5 x 22 mm, T25 Torx Pan Hd.)	4
12	660918001	Screw (M5 x 14 mm, T25 Torx Pan Hd.)	3
13	678321001	Damper Spring	1
14	660917003	Screw (M5 x 0.8 mm, T25 Torx Pan Hd.)	4
15	660918004	Screw (M5 x 14 mm, T25 Torx Pan Hd.)	2
16	561421001	Oil Filter Grommet	1
17	901376002	Band Stopper	1
18	561449001	Pipe In Oil Pump Rubber	1
19	678407001	Cone Spring	1
20	561428001	Rubber Damper	1
21	518442006	Engine Case	1
22	518411001	Pin (Oil Pump Outlet)	1
23	561426001	Damper Rubber	1
24	518435001	Damper Cap	1
25	678320001	Eyelet	1
26	518413001	Joint For Pipe In Comp	1
27	563968002	Oil Pump Rubber Tube (Outlet)	1
28	518434001	Damper Cap (T)	1

KEY NO.	PART NO.	DESCRIPTION	QTY.
29	660503006	Bar Stud (5/16-18 x 23.5 mm / 5/16-18 x 18 mm)	2
30	631034001	Hair Pin	1
31	518415005	Choke Rod	1
32	678332001	Damper Plate	1
33	291894001	Lead Wire Assembly (Red)	1
34	678322001	Damper Spring	1
35	660918002	Screw (M5 x 27 mm, T25 Torx Pan Hd.)	4
36	518691001	Handle	1
37	870174002	* Spark Plug (Torch/L7RTC)	1
38	310535001	Clutch	1
39	678313002	Thrust Plate	1
40	309418001	Clutch Drum	1
41	681933001	Clutch Drum Needle Bearing	1
42	660916003	Screw (M4 x 14 mm, T20 Torx Pan Hd.)	4
43	518414001	Oil Pump Cover	1
44	518865001	Oil Pump Drive Gear	1
45	638289001	Washer (ID10.2 x OD18 x 1t)	1
46	309516001	Oil Pump	1
47	660931001	Screw (M4 x 33 mm, T25 Torx Pan Hd.)	1
48	631035004	Chain Catcher	1
49	660916001	Screw (M4 x 12 mm, T20 Torx Pan Hd.)	1
50	638309003	Chain Guard Plate	1
51	311458001	Exhaust Assembly	1
52	307246005	Chassis & Handle Components	1
53	660922001	Screw (M4 x 10 mm, T20 Torx Pan Hd.)	2
54	660916003	Screw (M4 x 14 mm, T20 Torx Hd.)	2
55	291893001	Lead Wire Assembly (Black)	1
56	941012093	Chain Brake Label (RY3714)	1
	941012095	Chain Brake Label (RY3716)	1
57	941009044	Warning Label	1

\* Standard Hardware Item – May Be Purchased Locally



# RY3714/R3714VNM/R3716/R3716VNM

## PARTS LIST – FIGURE A (cont.)

KEY NO.	PART NO.	DESCRIPTION	QTY.
58	941012097	Starting Label (Right)	1
59	941012096	Starting Label (Left)	1
60	941851430	Starting House Label (R3714)	1
	941012092	Starting House Label (R3716)	1
61	678311001	Hex Nut (M5, Muffler)	2
62	638293004	Muffler Bracket	1
63	309377006	Muffler	1
64	901380001	† Gasket (Muffler)	1
65	660915001	Screw (M5 x 62 mm, Square Hd.)	2
66	518864003	Heat Dam	1
67	662395001	Bolt (M9 x 19 mm, T25 Torx Pan Hd.)	2
68	570243003	Intake Boot	1
69	678694002	Intake Bracket	1
70	308054203	Carburetor Assembly	1
71	518465002	Air Box Base	1
72	660454015	Screw (M5 x 44 mm, T25 Torx Hd., Carburetor)	2
73	560873013	Foam Air Filter	1
74	534173001	Air Filter Retainer	1
75	901212004	14 in. Chain (3/8LP, 52DL, RY3714)	1
	901361002	16 in. Chain (3/8LP, 56DL, RY3716)	1
76	311482001	14 in. Guide Bar Assembly (Inc. Key No. 88, RY3714)	1
	311482002	16 in. Guide Bar Assembly (Inc. Key No. 88, RY3716)	1

KEY NO.	PART NO.	DESCRIPTION	QTY.
77	940654088	Combustion Warning Label	1
78	660917002	Screw (M5 x 14 mm, T25 Torx Pan Hd.)	2
79	941009045	Pull To Release Brake Label	1
80	631055005	Combination Wrench	1
81	309893007	* Short Block	1
82	690688001	* Woodruff Key (Used with Key 83 Only)	1
83A	309001004	* Flywheel Assembly (B.D.C. 7/30/21)	1
83B	309001005	* Flywheel Assembly (A.D.C. 7/30/21)	1
84	309266003	Ignition Assembly	1
85	690689001	Hex Flange Nut (M8)	1
86	941851424	Bar Cover Label (R3714)	1
	941851424	Bar Cover Label (R3716)	1
87	678339003	Hex Nut (5/16-18)	2
88	314926001	Bar Nose Kit	1
	<b>Not Shown:</b>		
	995000483	Operator's Manual	
	580438012	14 in. Scabbard (RY3714)	
	580699012	16 in. Scabbard (RY3716)	
	308552006	Carrying Case	

### † Non-Reusable Parts

‡ Models before date code 7/30/21 use keys 82 & 83A. When replacing key 81 on these models, you must also order key 83B as keys 82 & 83A can no longer be used. Models after date code 7/30/21 use key 83B only; key 82 is not used on these models.

**PARTS LIST — FIGURE B**

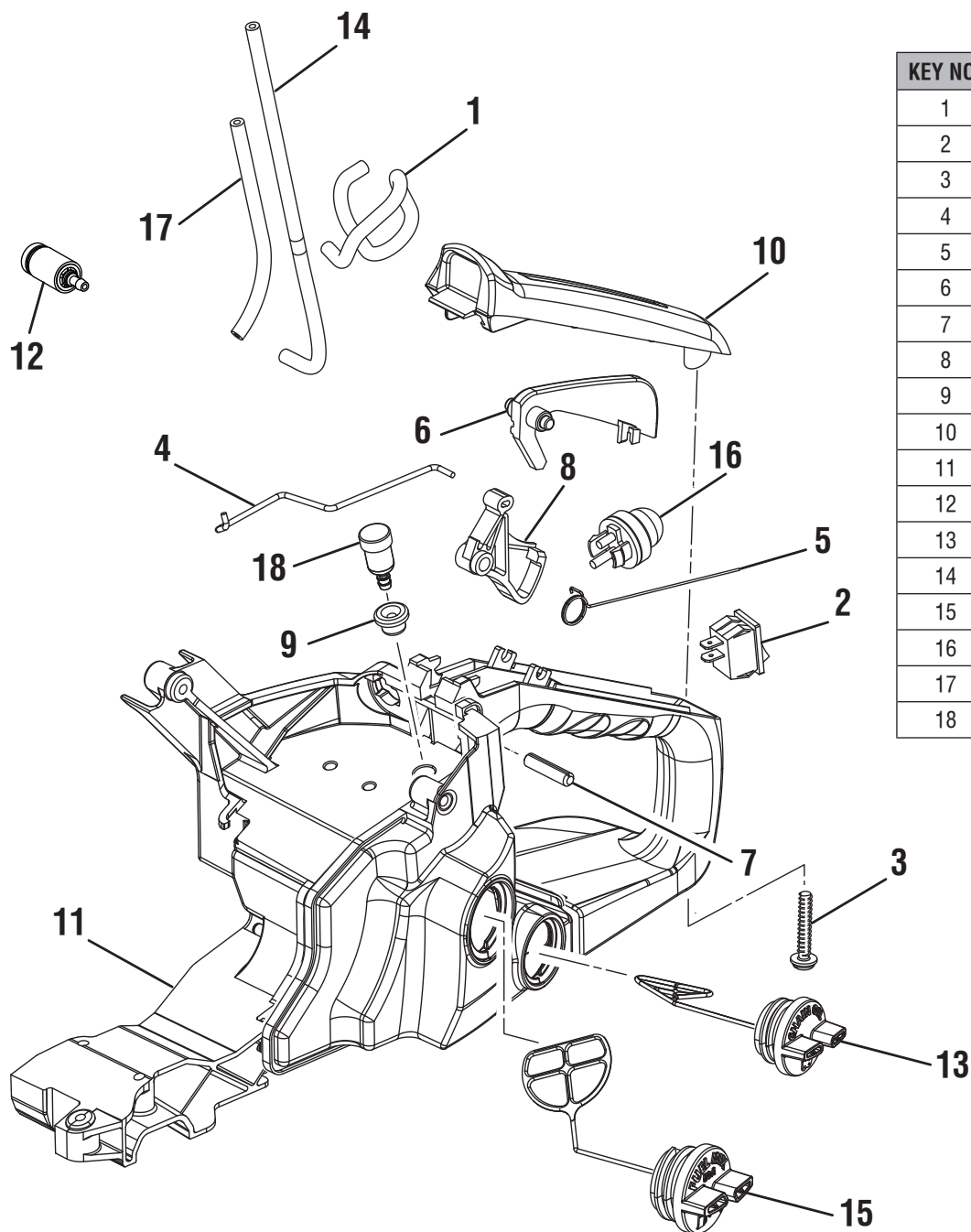

KEY NO.	PART NO.	DESCRIPTION	QTY.
1	570373019	Fuel Hose (Primer Assembly to Carburetor, 160 mm)	1
2	760961009	Switch	1
3	660918002	Screw (M5 x 27 mm, T25 Torx Pan Hd.)	1
4	638295001	Throttle Rod	1
5	678325001	Throttle Spring	1
6	518428004	Safety Lockout	1
7	638296001	Spring Pin	1
8	518466004	Trigger	1
9	561424001	Grommet	1
10	518429001	Grip Cover	1
11	308550008	Handle	1
12	300759011	Fuel Filter Assembly	1
13	308612006	Chain Oil Cap	1
14	562967003	LP-1500 Tubing (205.00 mm)	1
15	308611005	Fuel Cap Assembly	1
16	300780003	Primer Assembly	1
17	570373017	Fuel Hose (Primer Assembly to Tank, 153 mm)	1
18	308583001	Fuel Breather Assembly	1

**FIGURE B**

## PARTS LIST — FIGURE C

KEY NO.	PART NO.	DESCRIPTION	QTY.
1	311455002	‡ Crankcase & Crankshaft Assembly	1
2	903036002	† Crankcase Gasket	1
3	640213001	Cylinder	1
4	660613003	Screw (M5 x 20 mm, T25 Torx Hd.)	4
5	698288001	Piston Ring	2
6	309120005	Piston	1
7	620719001	Piston Pin	1
8	678077001	Piston Pin Clip	2
9	678078002	Needle Bearing	1

† Non-Reusable Parts

‡ When replacing key 1, models before date code 7/30/21 must also order key 83B Flywheel Assembly on page 4. This assembly has an integrated key, so your existing Woodruff Key will no longer be needed.

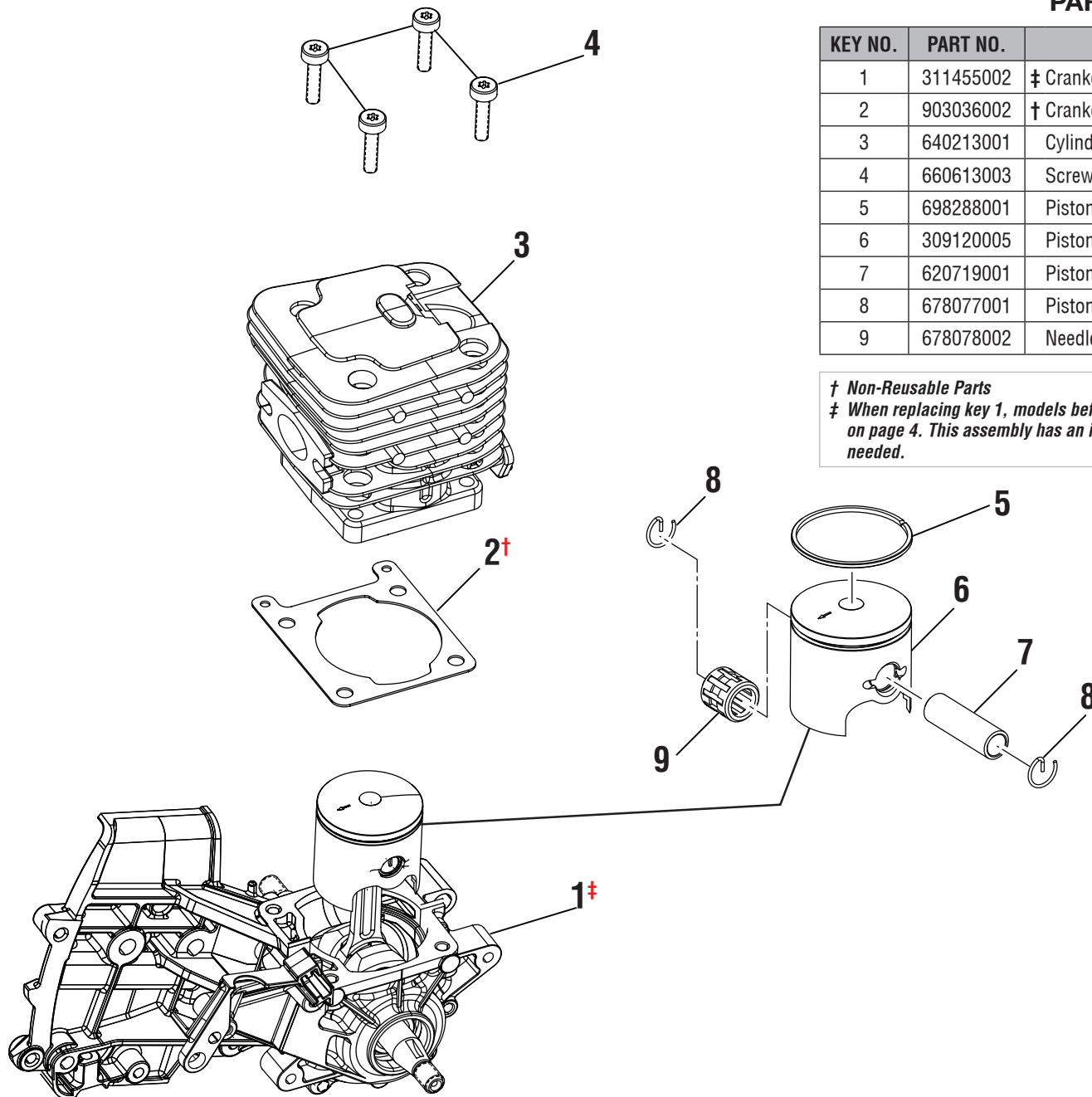

FIGURE C