

RYOBI
25cc String Trimmers
Repair Sheet

Item Numbers

**RY251PH, RY252CS, RY253SS,
RY251PHVNM, RY252CSVNM, RY253SSVNM**

Manufacturing Numbers

**090333053, 090333054, 090333055,
095333107, 095333108, 095333109**

TECHTRONIC INDUSTRIES POWER EQUIPMENT

P.O. Box 1288, Anderson, SC 29622

Phone 1-800-860-4050

www.ryobitools.com

FIGURE A

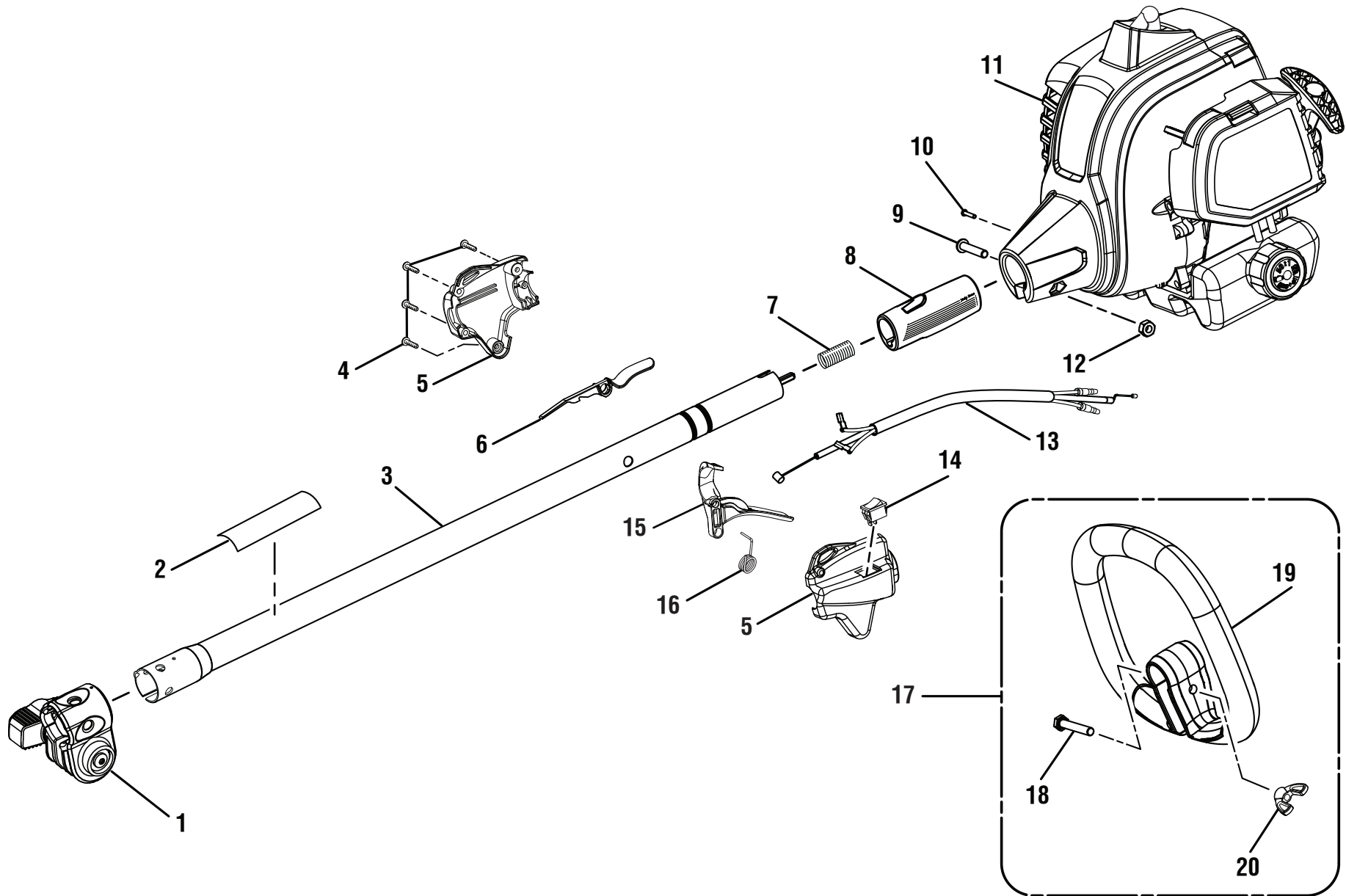

PARTS LIST (FIGURE A)

KEY NO.	PART NUMBER	DESCRIPTION	QTY
1	315386001	Boom Clamp Assembly	1
2	940657164	Warning Icon Label.....	1
3	205370001	Upper Boom Assembly (Inc. Key Nos. 1-2).....	1
4	660563002	Screw (M4 x 20 mm, T20 Torx Hd. S.T.)	4
5	310831005	Control Handle Assembly (Inc. Key No. 4)	1
6	518695009	Trigger Lock.....	1
7	690140011	Compression Spring.....	1
8	570234010	Rear Handle Grip	1
9	T660697001	Screw (M6 x 30 mm, T27 Torx Button Hd.)	1
10	660925011	Screw (M4 x 8 mm, T20 Torx Pan Hd. S.T.).....	1
11	205044002	Powerhead Assembly w/Labels	1
12	678029002	Hex Nut (M6 x 1).....	1
13	307318001	Throttle Cable and Wire Assembly	1
14	760961002	On/Stop Switch	1
15	518696020	Trigger.....	1
16	690694002	Trigger Spring	1
17	308991003	Front Handle Assembly (Inc. Key Nos. 18-20).....	1
18	660643008	Screw (1/4-20 x 40 mm, Cap Hex Hd.)	1
19	526764002	Front Handle.....	1
20	518949001	Wing Nut (1/4-20)	1
	NOT SHOWN		
	998000028	Operator's Manual	
	5-18-20		
	(Rev:01)		

RYOBI 25cc STRING TRIMMERS – ITEM NO. RY251PH, RY252CS, RY253SS, RY251PHVNM, RY252CSVNM, RY253SSVNM

FIGURE B

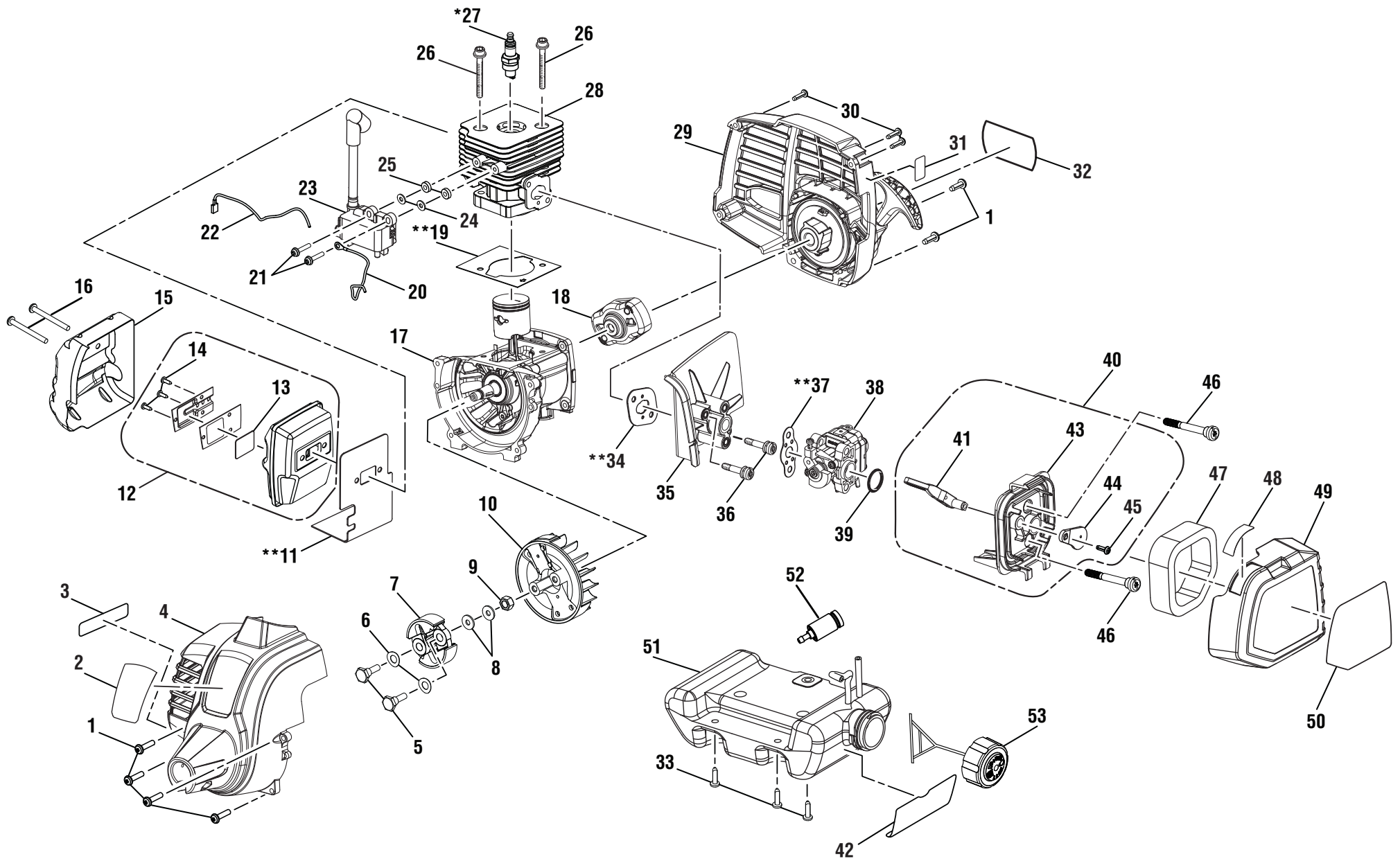

RYOBI 25cc STRING TRIMMERS – ITEM NO. RY251PH, RY252CS, RY253SS, RY251PHVNM, RY252CSVNM, RY253SSVNM

PARTS LIST (FIGURE B)

KEY NO.	PART NUMBER	DESCRIPTION	QTY
1	660344001	Screw w/Washer (M5 x 20 mm, T20 Torx Pan Hd.).....	6
2	940627041	Logo Label (Front)	1
3	940654088	Combustion Warning Label.....	1
4	205082001	Front Housing Assembly (Inc. Key Nos. 2-3).....	1
5	660353001	Clutch Shoulder Bolt (M6 x 22.5 mm, Hex Hd.).....	2
6	690696001	Curved Washer	2
7	307091001	Clutch Assembly.....	1
8	690695001	Washer (ID6 x OD15 x 1.2t)	2
9	690689001	Flywheel Nut.....	1
10	307156001	Flywheel.....	1
11	630002032	** Muffler Gasket	1
12	300748043	Muffler Assembly (Inc. Key Nos. 13-14).....	1
13	638268001	Screen	1
14	660870001	Screw (6-20 x 1/4 in., T20 Torx Pan Hd. S.T.).....	3
15	638027002	Heat Shield	1
16	660347001	Screw (M5 x 50 mm, T25 Torx Pan Hd.).....	2
17	307192001	Crankcase Assembly.....	1
18	308004003	Starter Cup	1
19	900709007	** Gasket	1
20	290143002	Lead Wire (Red)	1
21	660968004	Screw w/Washer (M4 x 22 mm, T20 Torx Pan Hd. S.T.)....	2
22	290143001	Lead Wire (Black).....	1
23	291337008	Digital Module Assembly.....	1
24	690969001	Washer (ID4.2 x OD10 x 1t)	2
25	590462001	Spacer (Phenolic)	2
26	660342001	Screw (M5 x 22 mm, Soc. Hd.).....	2
27	870174002	* Spark Plug (Torch L7RTC)	1
28	642368001	Cylinder	1
29	307157002	Rear Housing and Starter Assembly (Inc. Key Nos. 31-32).....	1

KEY NO.	PART NUMBER	DESCRIPTION	QTY
30	660563002	Screw (M4 x 18 mm, T20 Torx Pan Hd. S.T.).....	3
31	941788001	Primer Bulb Location Label.....	1
32	940627042	Logo Label (Rear)	1
33	660970002	Shoulder Screw (M4 x 14 mm, T25 Torx Truss Hd. S.T.)...3	3
34	903279002	** Insulator Gasket	1
35	528275001	Heat Dam Insulator.....	1
36	T662210002	Screw (M5 x 30 mm, T25 Torx Pan Hd. S.T.).....	2
37	903034001	** Gasket	1
38	307160011	Carburetor Assembly (Inc. Key No. 39).....	1
39	563841001	Carburetor O-Ring.....	1
40	307191001	Airbox Base Assembly (Inc. Key Nos. 41-45).....	1
41	591442001	Choke Lever	1
42	940864004	Fuel Mixture Label	1
43	591440001	Air Box Base.....	1
44	590946001	Choke Plate	1
45	660345001	Screw (M4 x 12 mm, T20 Torx Pan Hd. S.T.).....	1
46	660454020	Shoulder Screw (M5 x 45 mm, T25 Torx Pan Hd.)	2
47	560873001	Air Filter	1
48	940647111	Choke Position Label	1
49	308649003	Airbox Cover (Inc. Key Nos. 48 & 50).....	1
50	940686168	Starting Instructions Label	1
51	308682055	Fuel Tank and Cap Assembly (Inc. Key Nos. 42 and 52-53).....	1
52	310976001	Fuel Filter	1
53	310816018	Fuel Cap Assembly.....	1
Not Shown:			
	000998930	Spark Arrestor Kit (Inc. Key Nos. 13-14)	
	120900307	High Altitude Kit (Not Included)	

* Standard Hardware Item – May Be Purchased Locally

** Non-Reuseable Parts = Keys 11, 19, 34 and 37

RYOBI 25cc STRING TRIMMERS – ITEM NO. RY251PH, RY252CS, RY253SS, RY251PHVNM, RY252CSVNM, RY253SSVNM

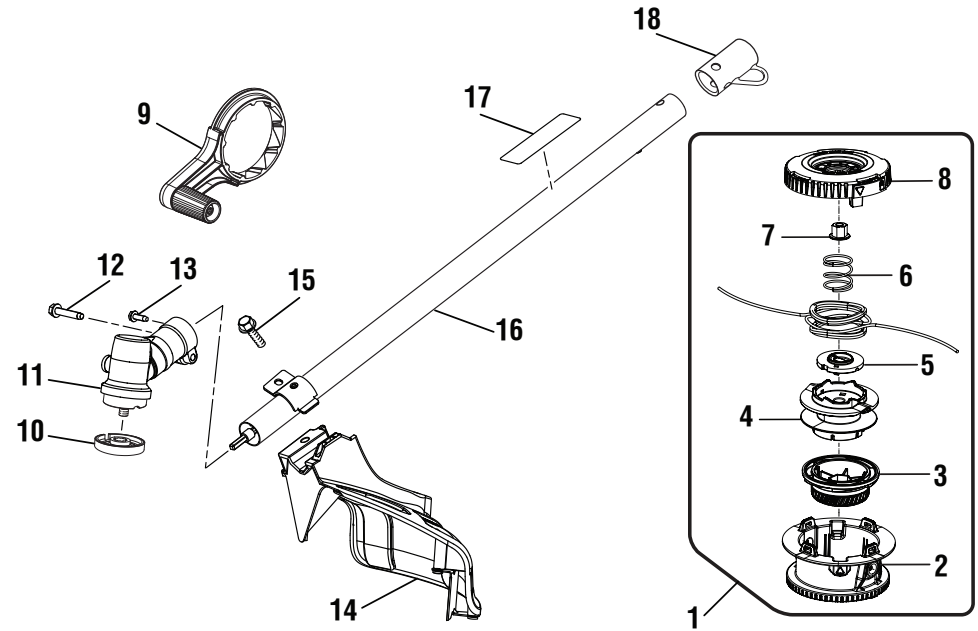
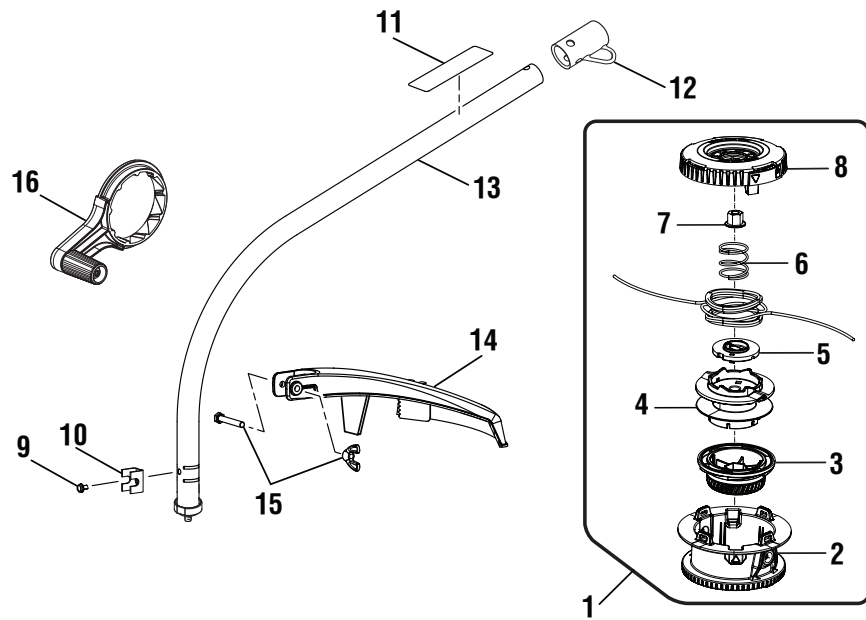

KEY NO.	PART NUMBER	DESCRIPTION	QTY
1	314608001	Trimmer Head Assembly (.095) (Inc. Key Nos. 2-8).....	1
2	537189001	Bump Head	1
3	530455002	Bump Knob (Green).....	1
4	530670001	Spool	1
5	529803001	String Guide.....	1
6	679958001	Compression Spring.....	1
7	662569001	Hex Nut (M8).....	1
8	314796001	Locking Assembly	1
9	660647001	Screw (#10-32 x 3/8 in., Hex Washer Hd. S.T.)	1
10	638001001	Clamp	1
11	940657165	Warning Icon Label.....	1
12	518019002	Storage Hanger Cap.....	1
13	205371001	Curved Shaft Assembly (Inc. Key Nos. 9-12)	1
14	308744010	Grass Deflector Assembly (Inc. Key No. 15)	1
15	205012001	Fastener Kit	1
16	532048001	Crank Handle.....	1

KEY NO.	PART NUMBER	DESCRIPTION	QTY
1	314608002	Trimmer Head Assembly (.095) (Inc. Key Nos. 2-8)	1
2	537189001	Bump Head	1
3	530455002	Bump Knob (Green)	1
4	530670001	Spool	1
5	529803001	String Guide	1
6	679958001	Compression Spring	1
7	662568002	Hex Nut (M8, L.H. Thread)	1
8	314796001	Locking Assembly	1
9	532048001	Crank Handle	1
10	678011001	Flanged Washer	1
11	308210009	Gear Case Assembly.....	1
12	660642001	Screw (1/4-20 x 1-1/4 in., Hex Washer Hd. S.T.)	1
13	660641001	Screw (10-24 x 5/8 in., Hex Washer Hd. S.T.)	1
14	308473005	Grass Deflector Assembly (Inc. Key No. 15).....	1
15	660738002	Screw (1/4-20 x 7/8 in., Hex Hd.).....	1
16	205372001	Straight Shaft Assembly (Inc. Key Nos. 17-18).....	1
17	940657165	Warning Icon Label	1
18	518019002	Storage Hanger Cap	1