

RYOBI
10 in. TABLE SAW
MODEL NUMBER RTS22/RTS22T
REPAIR SHEET

ONE WORLD TECHNOLOGIES, INC.
P.O. Box 1288, Anderson, SC 29622 • Phone 1-800-525-2579
www.ryobitools.com

RYOBI 10 in. TABLE SAW – MODEL NUMBER RTS22/RTS22T

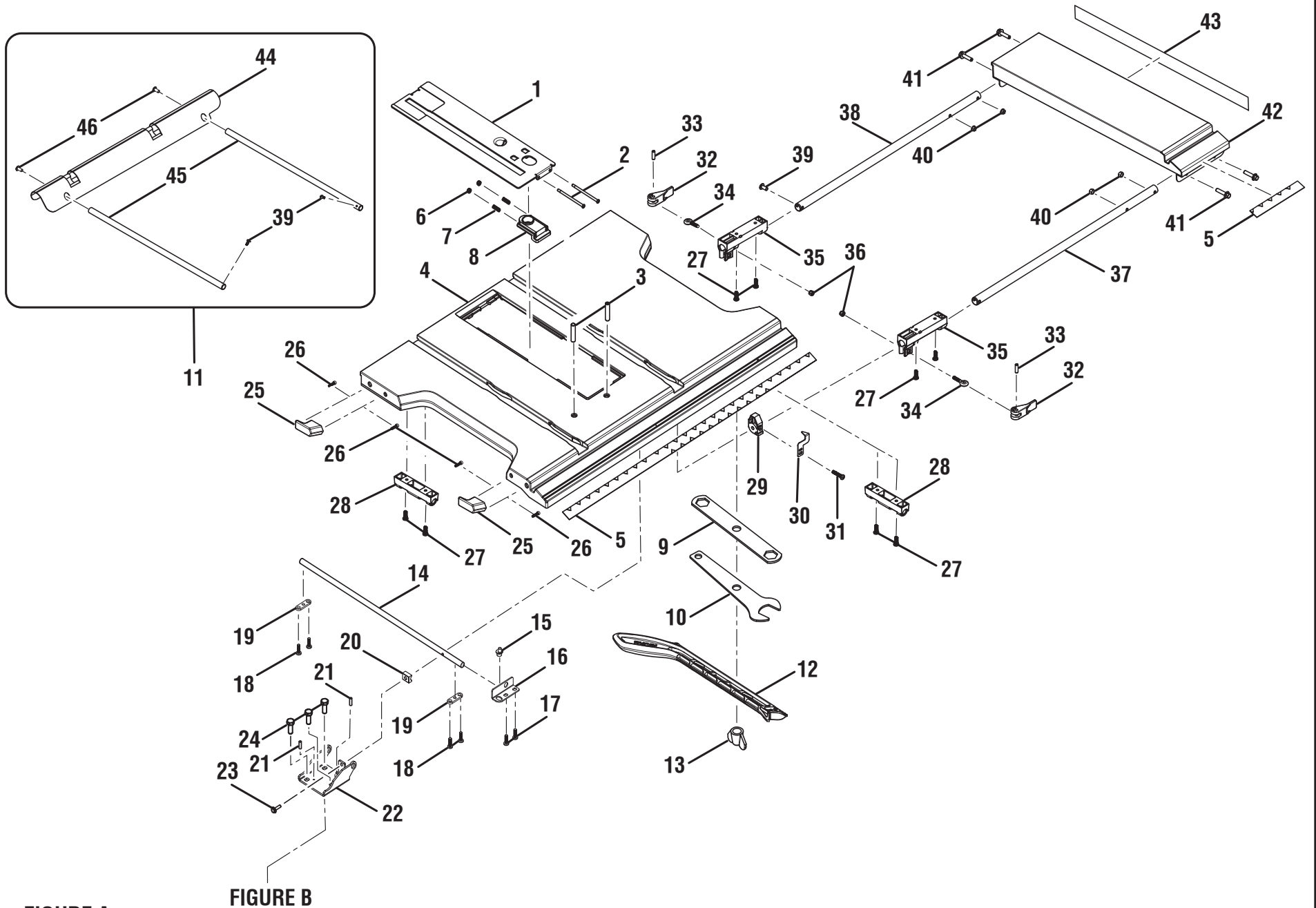

FIGURE A

FIGURE B

RYOBI 10 in. TABLE SAW – MODEL NUMBER RTS22/RTS22T

The model number will be found on a label attached to the cabinet. Always mention the model number in all correspondence regarding your **10 in. TABLE SAW** or when ordering parts.

PARTS LIST FOR FIGURE A

KEY NO.	PART NUMBER	DESCRIPTION	QTY	KEY NO.	PART NUMBER	DESCRIPTION	QTY
1	089240015704	Throat Plate Assembly (Inc. Key Nos. 2 and 6-8)	1	26	089240016027	Screw (M4 x 15 mm, Hex. Soc. Hd.)	4
2	089240015100	Screw (M4 x 70 mm, Button Soc. Hd.)	2	27	089110101014	Screw (#10 x 1/2 in.)	8
3	089015001001	Set Screw (M8 x 30 mm)	2	28	089037011020	Out Feed Support Holder	2
4	089240016703	Table Assembly (Inc. Key Nos. 5 and 13)	1	29	089240016123	Rip Indicator Mount	1
5	089240016901	Rip Scale Label	1	30	089240016122	Right Scale Indicator	1
6	089240015089	Lock Nut (M4)	2	31	089110101041	Screw (M4 x 25 mm, Truss Hd.)	1
7	089240015095	Compression Spring	2	32	089240016036	Lock Lever	2
8	089240015094	Latch	1	33	089110101016	Spring Pin	2
9	080015001505	Combination Blade Wrench	1	34	089110101015	Lever Screw	2
10	080015001506	Open End Wrench	1	35	089110101013	Extension Table Holder	2
11	089240016120	Rear Outfeed Support Assembly (Inc. Key Nos. 39 and 44-46)	1	36	089110101012	Lock Nut (M5)	2
12	089037007006	Push Stick	1	37	089240016124	Front Extension Rod	1
13	089240015106	Wing Nut (5/16-18)	1	38	089240016125	Rear Extension Rod	1
14	089240015041	Rod	1	39	089110101011	Screw (M4 x 10 mm, Truss Hd.)	3
15	089110101022	Eccentric Shaft	1	40	089240016006	Lock Nut (M6)	4
16	089110101020	Adjustment Plate	1	41	089037011027	Screw (M6 x 25 mm)	4
17	089110101021	Screw w/Washer (M6 x 15 mm, Hex Soc. Hd.)	2	42	089240016040	Extension Table Assembly (Inc. Key Nos. 5 and 43)	1
18	089110101024	Screw w/Washer (M6 x 12 mm, Hex. Soc. Hd.)	4	43	089240016903	Stand Instruction Label	1
19	089110101023	Pivot Bracket Plate	2	44	089240016085	Rear Support	1
20	080015001443	Block	1	45	089037011019	Rear Rod	2
21	080015001445	Spring Pin (D4 x 13 mm)	2	46	089110101146	Screw w/Washer (1/4-20 x 1/2 in., Pan Hd.)	2
22	089240015042	Upper Bracket	1	Not Shown:			
23	089037007011	Screw w/Washer (M5 x 20 mm, Hex Hd.)	1	089240015199	Optional Dado Throat Plate Assembly (Inc. Key Nos. 2 and 6-8)		
24	080015001446	Screw (1/4-20 x 3/4 in., Hex Flange Hd.)	3	089240015906	Styrofoam Removal Warning Label		
25	089240016028	Cord Wrap Support	2	995000231	Operator's Manual (089240052802)		
				1-28-20			
				(Rev:05)			

RYOBI 10 in. TABLE SAW – MODEL NUMBER RTS22/RTS22T

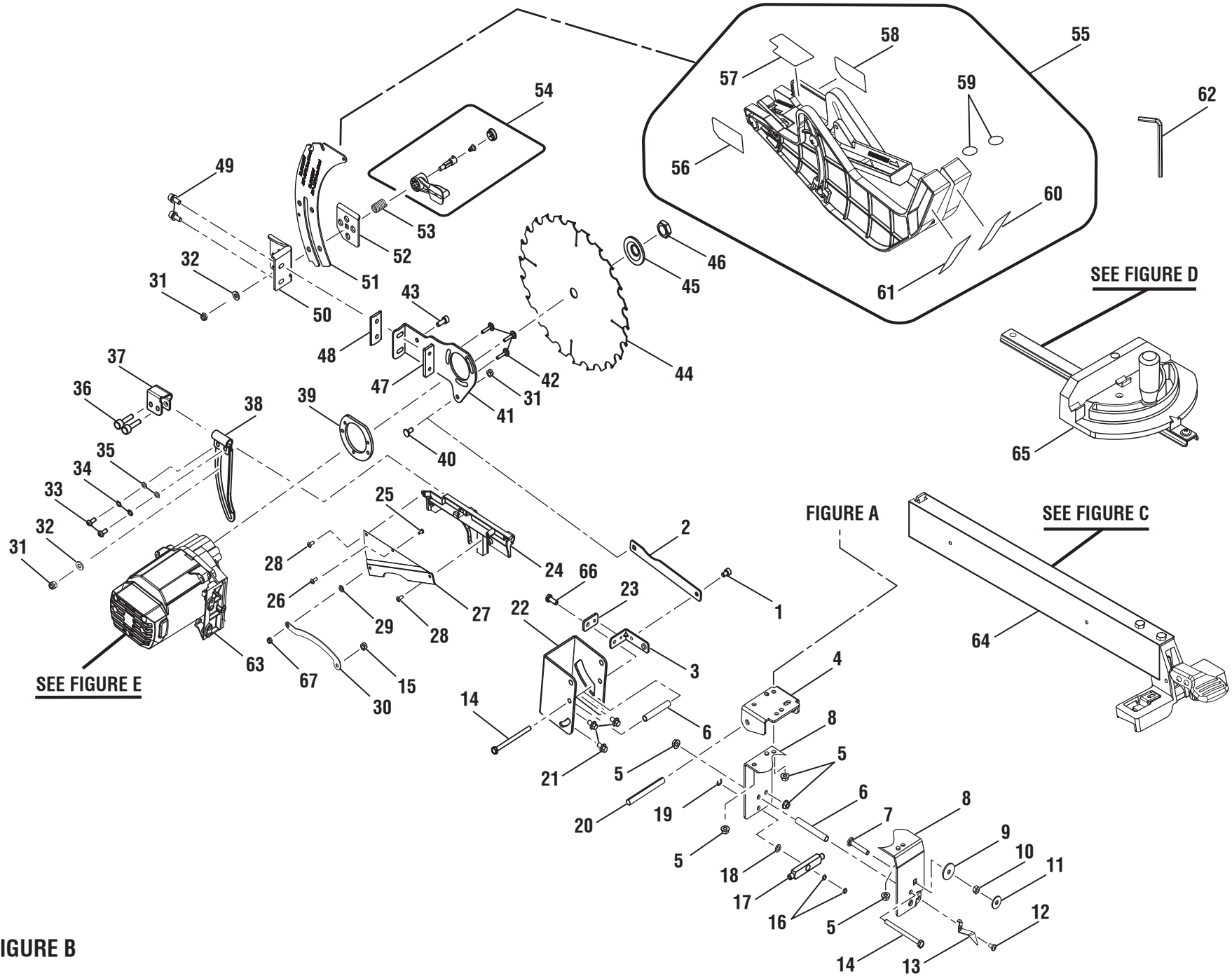

FIGURE B

RYOBI 10 in. TABLE SAW – MODEL NUMBER RTS22/RTS22T

The model number will be found on a label attached to the cabinet. Always mention the model number in all correspondence regarding your **10 in. TABLE SAW** or when ordering parts.

PARTS LIST FOR FIGURE B

KEY NO.	PART NUMBER	DESCRIPTION	QTY	KEY NO.	PART NUMBER	DESCRIPTION	QTY
1	089240015112	Screw (M6 x 8 mm, Special Hex. Soc. Hd.).....	1	29	089240015108	Washer (OD8 x ID4 x 1t)	1
2	089037007012	Pull Rod	1	30	089240015053	Linkage B.....	1
3	089240015045	Mounting Bracket	1	31	089110101101	Lock Nut (M6)	3
4	089240015035	Middle Bracket.....	1	32	089110101033	Washer (OD16 x ID1/4 x 1t)	2
5	080015001603	Lock Nut (1/4 in.)	6	33	089037007101	Screw (M5 x 10 mm, Button Hd.)	2
6	080015001449	Spacer	2	34	089037007100	Washer (D5)	2
7	089240015034	Carriage Bolt (1/4 in. x 45 mm)	1	35	089037007099	Washer (OD12 x ID5 x 1.5t)	2
8	089240015209	Work Plate.....	1	36	089240015072	Screw w/Washer (M5 x 25 mm).....	2
9	089037007102	Washer (OD20 x ID6.5 x 1.6t)	1	37	089240015073	Bracket	1
10	080015001455	Hex Nut (1/4-20)	1	38	089037007098	Support Plate.....	1
11	089037011048	Washer (OD20 x ID6.5 x 2.5t)	1	39	089037007097	Lever Support.....	1
12	089240015054	Screw w/Washer (M4 x 8 mm, Round Hd.)	1	40	089037007015	Carriage Bolt (M6 x 15.5 mm).....	1
13	089240015208	Bevel Indicator.....	1	41	089037007019	Lever	1
14	080015001437	Screw (1/4-20 x 3-1/4 in., Hex Hd.).....	2	42	089037007017	Screw (M4 x 0.7 mm).....	3
15	089110101012	Lock Nut (M5)	1	43	089037007018	Screw (M6 x 15 mm, Hex Soc. Hd.)	1
16	089037007034	Hex Nut (3/8-16)	2	44	089240015207	Blade (10 in., 24 Tooth)	1
17	089037007033	Block.....	1	45	089110102100	Outer Blade Washer	1
18	089037011047	Washer (OD13 x ID6.5 x 0.5t)	1	46	080015001410	Blade Nut (5/8-18)	1
19	089037007029	C-Ring.....	1	47	089037007020	Clamp Lock.....	1
20	080015001458	Spring Pin (D8 x 90 mm).....	1	48	089037007021	Clamp	1
21	080015001436	Screw (M6 x 18 mm, Hex Flange Hd.).....	3	49	089037007022	Screw w/Washer (M6 x 20 mm, Hex Soc. Hd.)	2
22	089037007016	Motor Bracket.....	1	50	089037007023	Riving Knife Base.....	1
23	089240015047	Support Board	1	51	089240015076	Riving Knife.....	1
24	089240015048	Bracket (Guard Fabric).....	1	52	089037011030	Bracket	1
25	089240015049	Screw (M4 x 10 mm).....	1	53	089037007096	Compression Spring.....	1
26	089240015028	Screw (M4 x 12 mm, Round Hd.)	1	54	089037007709	Lever Assembly	1
27	089240015050	Guard Fabric.....	1				
28	089240015052	Screw (M4 x 10 mm, Round Hd.)	2				

RYOBI 10 in. TABLE SAW – MODEL NUMBER RTS22/RTS22T

The model number will be found on a label attached to the cabinet. Always mention the model number in all correspondence regarding your **10 in. TABLE SAW** or when ordering parts.

PARTS LIST FOR FIGURE B

KEY NO.	PART NUMBER	DESCRIPTION	QTY	KEY NO.	PART NUMBER	DESCRIPTION	QTY
55	089240015144	Blade Guard Assembly w/AKP (Inc. Key Nos. 56-61)	1	61	089037007910	Blade Guard Warning Label (Left End)	1
56	089037007912	Outer Guard Warning Label	1	62	089110102005	Hex Key Wrench (M5 x 75 mm)	1
57	089037007908	Warning Label (Upper Barrier)	1	63	089240015187	Motor Assembly (See Figure F).....	1
58	089037007911	Inner Guard Warning Label.....	1	64	089240015155	Rip Fence Assembly (See Figure D)	1
59	089110113913	No Hands Warning Label.....	2	65	089240015174	Miter Gauge Assembly (See Figure E).....	1
60	089037007909	Blade Guard Warning Label (Right End).....	1	66	080015001446	Screw (1/4-20 x 3/4 in., Hex Flange Hd.).....	1
				67	089240015089	Lock Nut (M4)	1

RYOBI 10 in. TABLE SAW – MODEL NUMBER RTS22/RTS22T

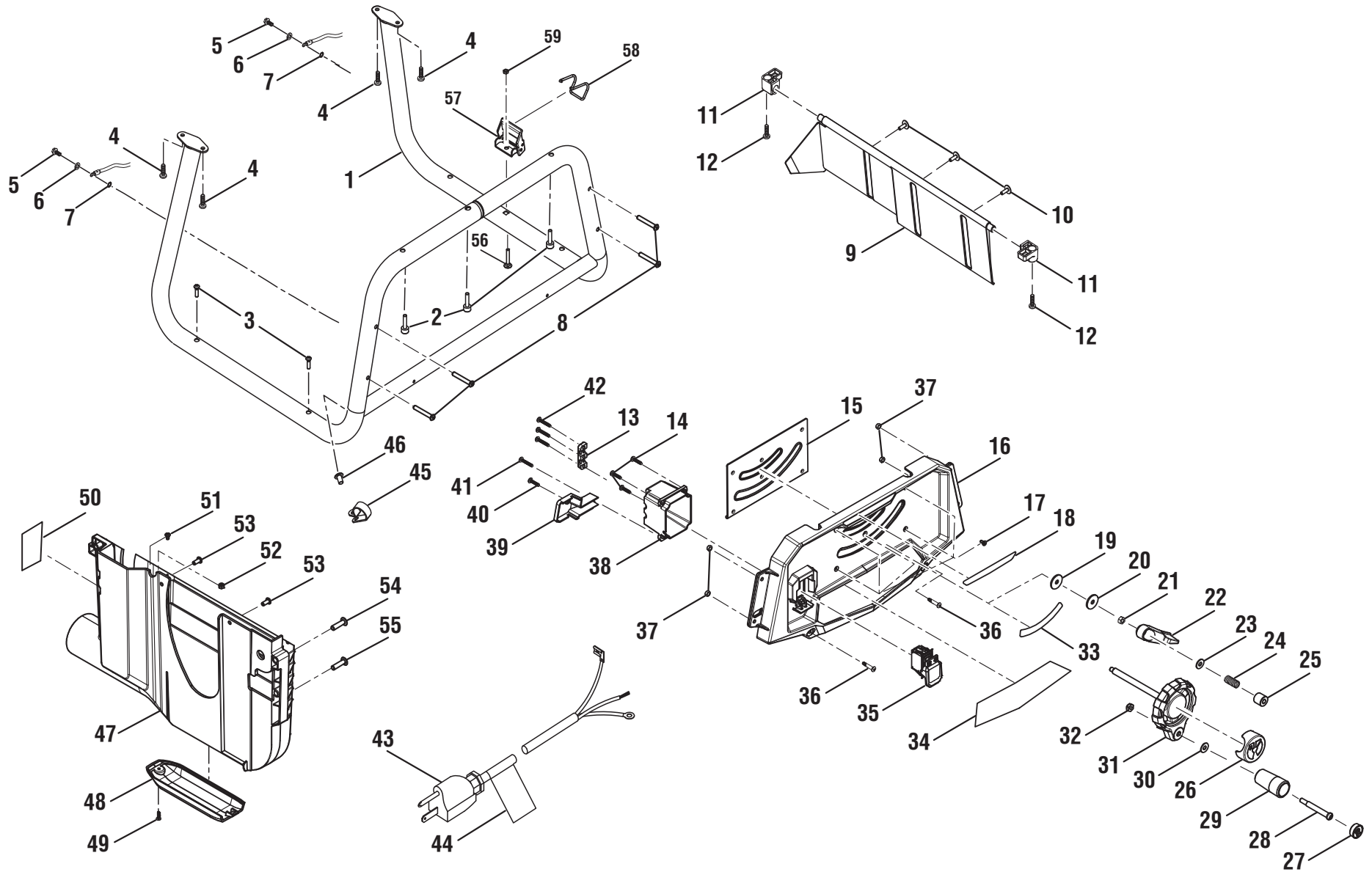

FIGURE C

RYOBI 10 in. TABLE SAW – MODEL NUMBER RTS22/RTS22T

The model number will be found on a label attached to the cabinet. Always mention the model number in all correspondence regarding your **10 in. TABLE SAW** or when ordering parts.

PARTS LIST FOR FIGURE C

KEY NO.	PART NUMBER	DESCRIPTION	QTY	KEY NO.	PART NUMBER	DESCRIPTION	QTY
1	089240015001	Frame.....	1	31	089240015011	Hand Wheel Assembly	1
2	089240015002	Screw (M6 x 40 mm, Button Hd.)	3	32	089110102180	Lock Nut (1/4-20).....	1
3	089240016119	Screw (M6 x 18 mm, Round Hd.)	2	33	089240015901	Bevel Scale Label	1
4	089240015004	Screw (M5 x 15 mm, Round Hd.)	4	34	089240015902	Front Panel Warning Label	1
5	089240015114	Screw (8-32 x 3/8 in., Hex Hd.)	2	35	089240015018	Switch.....	1
6	089240015115	Washer (D4)	2	36	089240015019	Screw (M5 x 12 mm, Truss Hd.)	2
7	080015001496	External Tooth Lock Washer (M4).....	2	37	089110101012	Lock Nut (M5)	4
8	089240015003	Screw (M5 x 30 mm, Round Hd.)	4	38	089240015021	Switch Box	1
9	089240015092	Dust Cover.....	1	39	089240015110	Ground Wire Cover.....	1
10	089240015093	Screw (M4 x 12 mm, Truss Hd.)	3	40	089240015111	Screw (M4 x 10 mm, Round Hd.)	1
11	089240015091	Holder	2	41	089240015109	Screw (M4 x 16 mm, Round Hd.)	1
12	089240015090	Screw (M5 x 12 mm, Truss Hd.)	2	42	089110101067	Screw (8-16 x 19.05 mm)	3
13	089110101069	Cord Clamp	1	43	089240015029	Power Cord Assembly (Inc. Key No. 44)	1
14	089240015028	Screw (M4 x 12 mm, Round Hd.)	3	44	089037007902	Power Cord Warning Label	1
15	089240015027	Reinforcement Plate	1	45	089110101081	Wire Clamp	1
16	089240015015	Front Panel Assembly (Inc. Key Nos. 18 and 33-34).....	1	46	089110101011	Screw (M4 x 10 mm, Truss Hd.)	1
17	080015001473	Screw (M4 x 7 mm, Flat Hd.).....	6	47	089240016701	Dust Chute Assy. (Inc. Key No. 50, RTS22)....	1
18	089240015903	Bevel Lock Lever Label	1		089240052701	Dust Chute Assy. (Inc. Key No. 50, RTS22T)..	1
19	089240015200	Plastic Washer (OD25 x ID6.5 x 2t)	1	48	089240015202	Dust Chute Door.....	1
20	089240015201	Washer (OD25 x ID6.5 x 1.6t)	1	49	089240015084	Screw (M4 x 10 mm, Truss Hd.)	1
21	080015001455	Hex Nut (1/4-20)	1	50	089240016902	Data Label (RTS22).....	1
22	089240015025	Bevel Lock Lever	1		089240052901	Data Label (RTS22T).....	1
23	089110101033	Washer (OD16 x ID1/4 in. x 1t)	1	51	089240015188	Screw (M4 x 5 mm, Truss Hd.)	1
24	080015001634	Compression Spring.....	1	52	089240015089	Lock Nut (M4)	1
25	089037007108	Cap	1	53	089240015116	Screw (M4 x 10 mm, Truss Hd.)	2
26	089240015007	Hand Wheel Cap	1	54	089240015088	Screw (M6 x 30 mm, Truss Soc. Hd.)	1
27	089240015008	Hand Grip Cap.....	1	55	089240015087	Screw (M6 x 20 mm, Truss Soc. Hd.).....	1
28	089240015009	Screw (1/4-20 x 55 mm)	1	56	089240016002	Screw (M6 x 33 mm, Soc. Cap Hd.).....	1
29	089240015010	Hand Grip	1	57	089240016004	Clamp Plate Assembly	1
30	080015001479	Washer (OD13 x ID1/4 in. x 1.5t)	1	58	089240016005	Wire Lock.....	1
				59	089240016006	Lock Nut (M6)	1

RYOBI 10 in. TABLE SAW – MODEL NUMBER RTS22/RTS22T

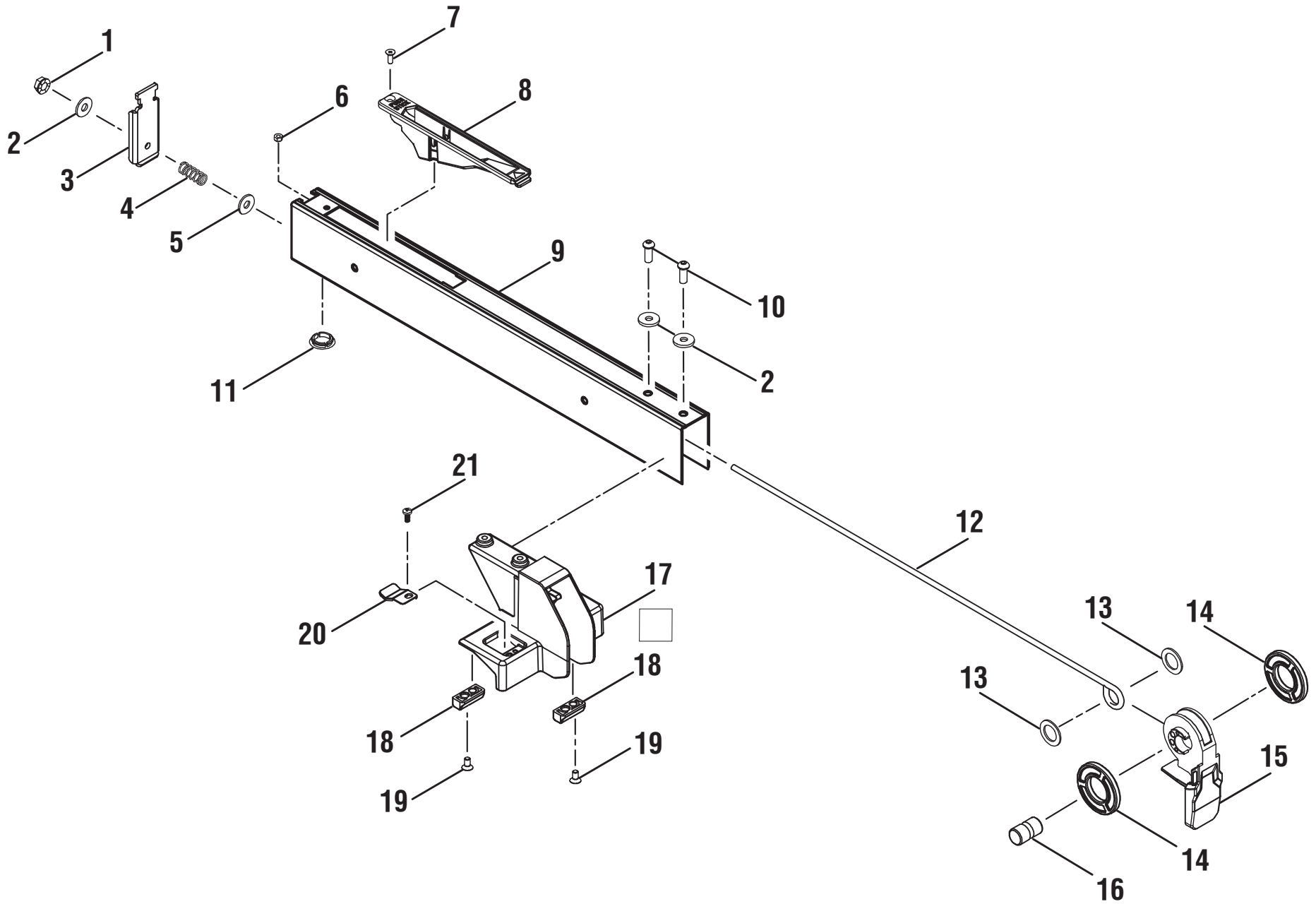

FIGURE D

RYOBI 10 in. TABLE SAW – MODEL NUMBER RTS22/RTS22T

The model number will be found on a label attached to the cabinet. Always mention the model number in all correspondence regarding your **10 in. TABLE SAW** or when ordering parts.

PARTS LIST FOR FIGURE D

KEY NO.	PART NUMBER	DESCRIPTION	QTY
1	089110101101	Lock Nut (M6)	1
2	089110101102	Washer (OD16 x ID6.5 x 1.5t)	3
3	089240015164	Rear Clamp	1
4	089110101104	Compression Spring	1
5	080015001479	Washer (OD13 x ID1/4 x 1.5t)	1
6	089240015089	Lock Nut (M4)	1
7	089240015173	Screw (M4 x 12 mm, Flat Hd.)	1
8	089240015172	Push Stick Holder	1
9	089240015162	Rip Fence.....	1
10	089110101107	Screw (M6 x 15 mm, Truss Soc. Hd.)	2
11	089110101120	Fence Block	1
12	089240015159	Rod	1
13	089110101108	Washer (OD25 x ID16 x 1.5t)	2
14	089110101115	Crank Gasket	2
15	089240015158	Fence Lever	1
16	089110101114	Crank Shaft.....	1
17	089240015167	Fence Bracket.....	1
18	089240015169	Glide Block	2
19	089240015170	Screw (8-32 x 8.5 mm, Flat Hd.).....	2
20	089240015168	Indicator.....	1
21	089240015197	Screw (M4 x 10 mm, Truss Hd.).....	1

RYOBI 10 in. TABLE SAW – MODEL NUMBER RTS22/RTS22T

The model number will be found on a label attached to the cabinet. Always mention the model number in all correspondence regarding your **10 in. TABLE SAW** or when ordering parts.

FIGURE E

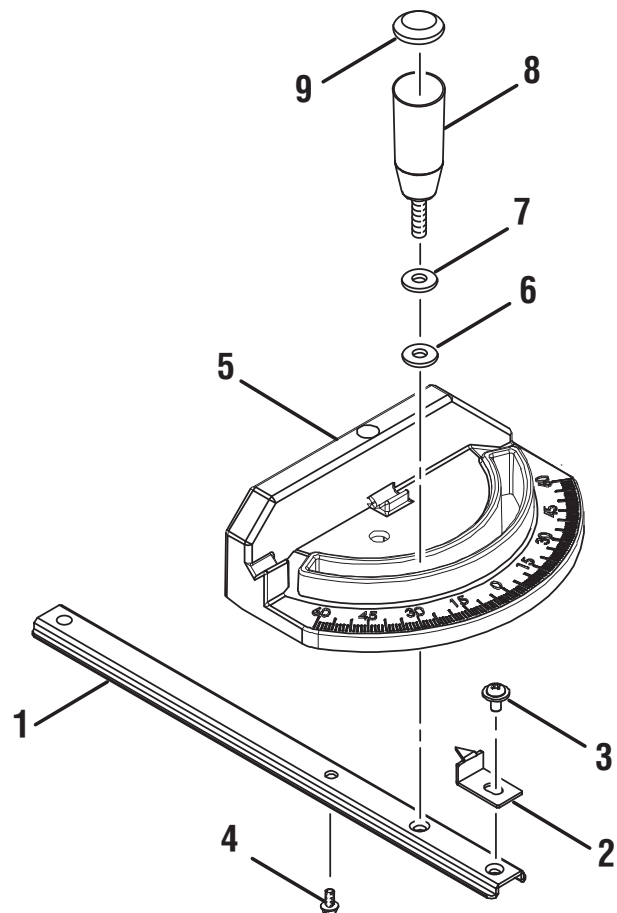

PARTS LIST FOR FIGURE E

KEY NO.	PART NUMBER	DESCRIPTION	QTY
1	089240015177	Miter Gauge Rod	1
2	080015001563	Pointer	1
3	080015001662	Screw (3/16-24 x 1/4 in., Round. Hd.)	1
4	089037007078	Screw (M4 X 14.8 MM)	1
5	089040002706	Miter Gauge	1
6	080015001475	Nylon Washer (OD16 x ID6.5 x 2t)	1
7	080015001560	Washer (OD16 x ID6.5 x 2t)	1
8	089040002005	Miter Gauge Knob	1
9	089040002006	Miter Gauge Cap	1

RYOBI 10 in. TABLE SAW – MODEL NUMBER RTS22/RTS22T

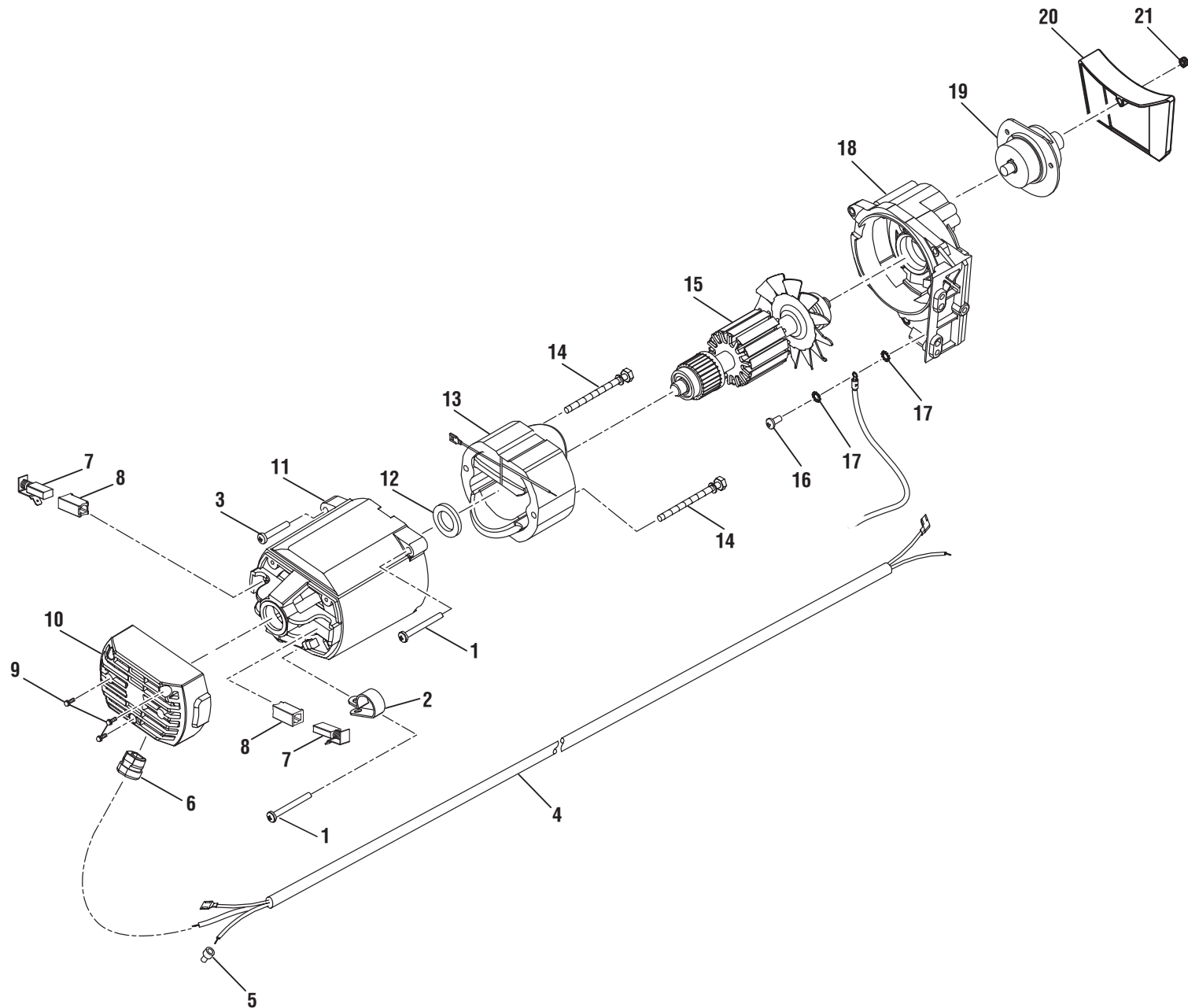

FIGURE F

NOTE: The assembly shown represents an important part of the double insulated system. To avoid the possibility of alteration or damage to the system, service should be performed by your nearest Ryobi Authorized Service Center. Contact your nearest Ryobi Authorized Service Center for service.

RYOBI 10 in. TABLE SAW – MODEL NUMBER RTS22/RTS22T

The model number will be found on a label attached to the cabinet. Always mention the model number in all correspondence regarding your **10 in. TABLE SAW** or when ordering parts.

PARTS LIST FOR FIGURE F

KEY NO.	PART NUMBER	DESCRIPTION	QTY
1	089240015141	Screw w/Washer (M5 x 60 mm, Round. Hd.).....	2
2	089110101081	Wire Clamp	1
3	089037011050	Screw w/Washer (M5 x 35 mm, Round. Hd.).....	1
4	089240015143	Motor Cord	1
5	089037007048	Wire Connector.....	1
6	089240015140	Strain Relief.....	1
7	080015001641	Brush Assembly.....	2
8	089037007050	Brush Holder.....	2
9	089240015028	Screw (M4 x 12 mm, Round Hd.)	3
10	089240015120	Motor End Cap	1
11	089240015121	Motor Housing	1
12	080015001424	Wavy Washer (M6 x 16 mm)	1
13	089037011028	Field Assembly.....	1
14	089290001182	Screw w/Washer (M5 x 65 mm, Truss Hd.).....	2
15	089037011708	Armature Assembly w/Bearings	1
16	089110101220	Screw (8-32 x 3/8 in, Truss Hd.)	1
17	080015001496	External Tooth Lock Washer (M4)	2
18	089240015702	Gear Box Assembly w/Bearing.....	1
19	089037007705	Arbor Assembly	1
20	089240015139	Gear Box Cover	1
21	089110101012	Lock Nut (M5)	1

RYOBI 10 in. TABLE SAW – MODEL NUMBER RTS22/RTS22T

The model number will be found on a label attached to the cabinet. Always mention the model number in all correspondence regarding your **10 in. TABLE SAW** or when ordering parts.

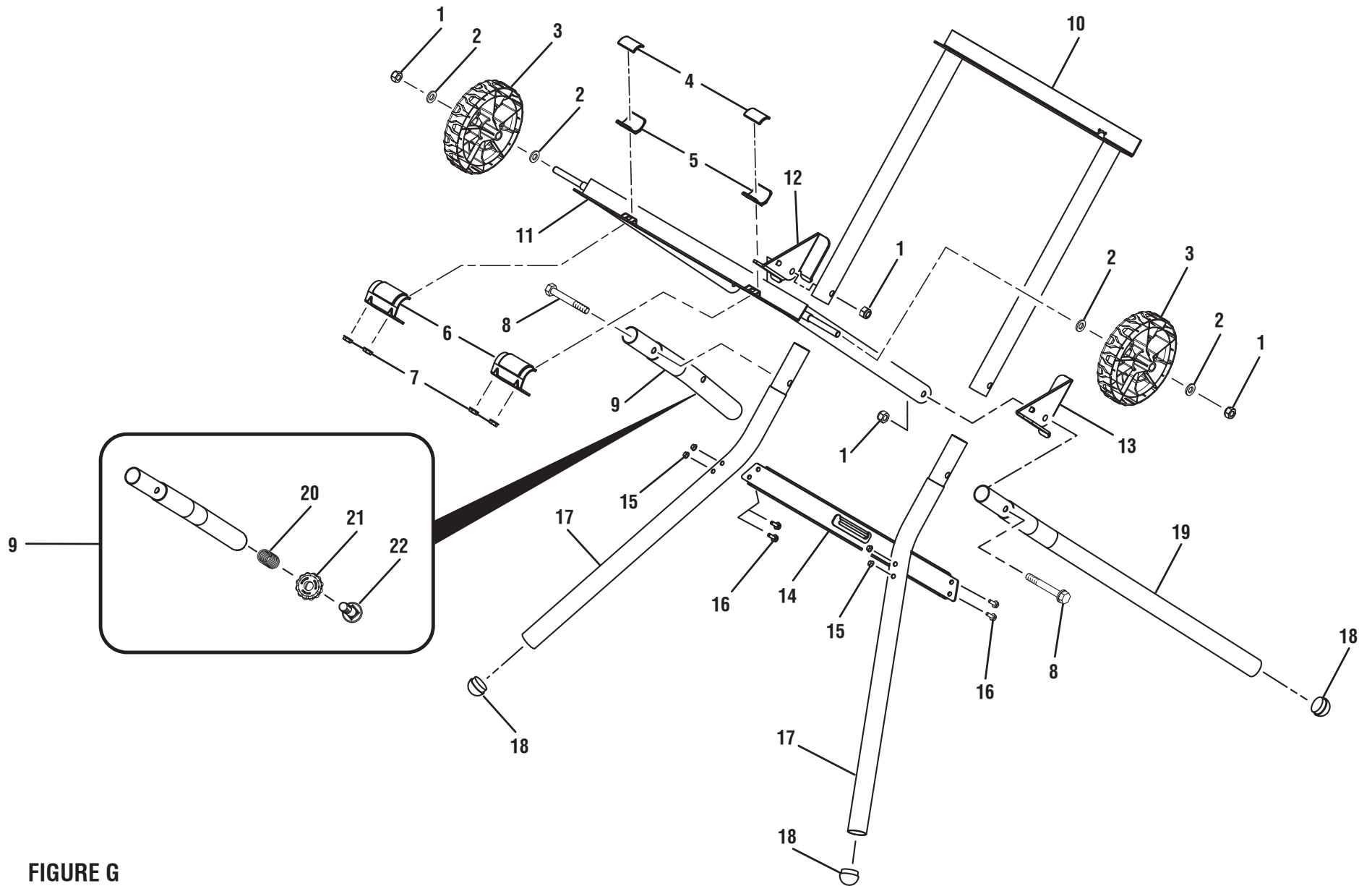

FIGURE G

RYOBI 10 in. TABLE SAW – MODEL NUMBER RTS22/RTS22T

The model number will be found on a label attached to the cabinet. Always mention the model number in all correspondence regarding your **10 in. TABLE SAW** or when ordering parts.

PARTS LIST FOR FIGURE G

KEY NO.	PART NUMBER	DESCRIPTION	QTY
1	000999130010	Lock Nut (M8)	4
2	089240016095	Washer (OD16 x ID8 x 2t)	4
3	089240016096	6 in. Wheel	2
4	089240016098	Upper Plate Bracket	2
5	089240016099	Lower Plate Bracket	2
6	089240016094	Clamp	2
7	089240016006	Lock Nut (M6)	4
8	089240015181	Screw (M8 x 65 mm, Hex Hd.).....	2
9	089240016093	Rear Extension Tube Assembly (Inc. Key Nos. 20-22)	1
10	089240015185	Inner Leg Tube	1
11	089240015184	Outer Leg Tube	1
12	089240015183	Rear Support Plate	1
13	089240015186	Front Support Plate	1
14	089240016091	Cross Brace	1
15	089240016090	Lock Nut (M5)	4
16	089240016089	Screw (M5 x 35 mm).....	4
17	089240016092	Inner Extension Tube	2
18	080009019087	End Cap	3
19	089240015180	Outer Extension Tube	1
20	089240016102	Compression Spring	1
21	089240016103	Adjustment Knob	1
22	089240016104	Carriage Bolt (M12 x 55 mm).....	1
 Not Shown:			
	089240016702	Complete Stand Assembly (Inc. Key Nos. 1-22)	

RYOBI 10 in. TABLE SAW – MODEL NUMBER RTS22/RTS22T

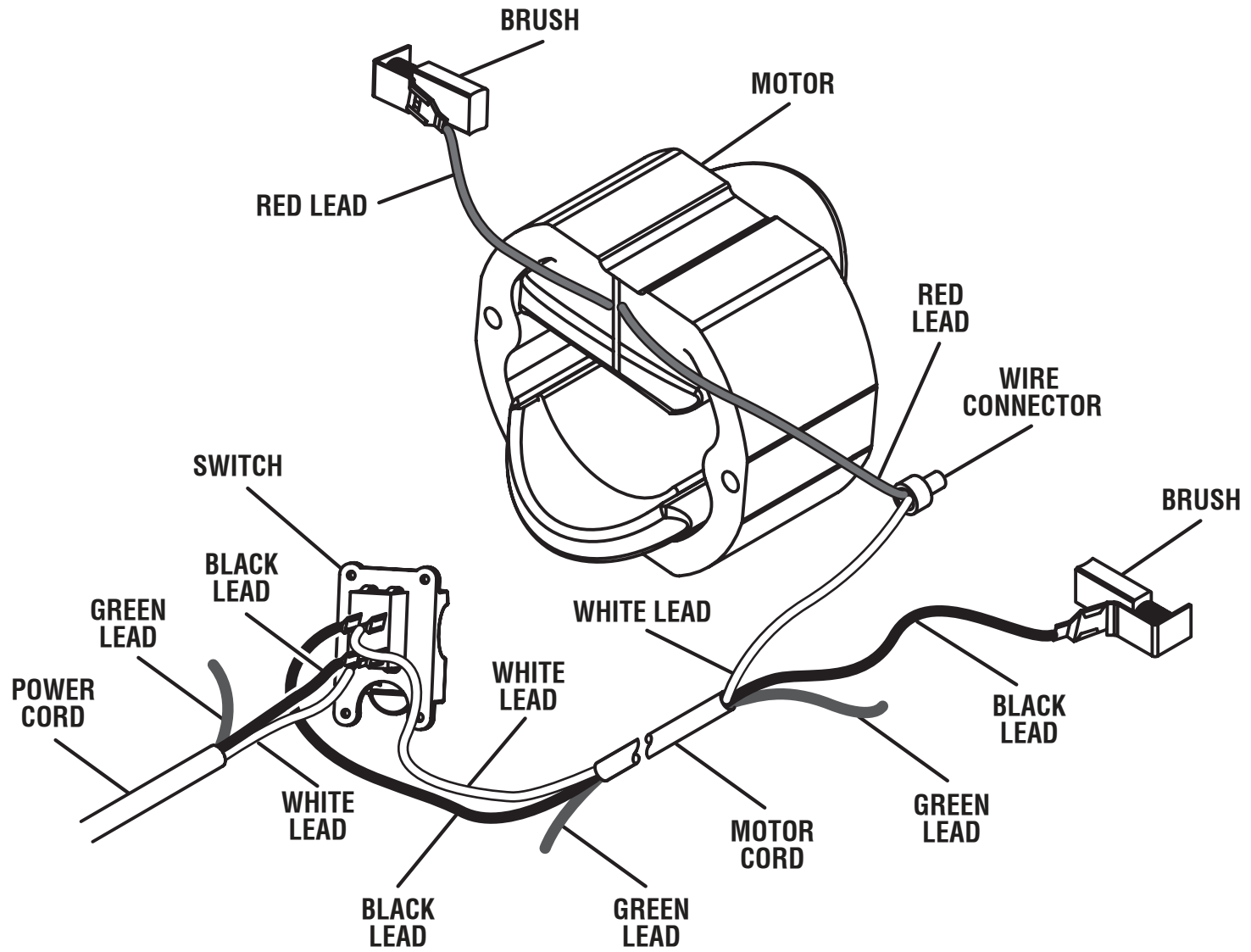

WIRING DIAGRAM