

RYOBI
10 in. TABLE SAW
MODEL NUMBER RTS21G
REPAIR SHEET

RYOBI 10 in. TABLE SAW – MODEL NUMBER RTS21G

The model number will be found on a label attached to the cabinet. Always mention the model number in all correspondence regarding your **10 in. PORTABLE TABLE SAW** or when ordering parts.

PARTS LIST FOR FIGURE A

KEY NO.	PART NUMBER	DESCRIPTION	QTY	KEY NO.	PART NUMBER	DESCRIPTION	QTY
1	089040003701	Throat Plate	1	28	0101010501	Spacer	1
2	089037011004	Magnet.....	2	29	410162701	Screw (1/4-20 x 3/4 in., Cheese Hd.).....	4
3	089015001001	Screw (M8 x 30 mm).....	1	30	0101010304	Upper Bracket	1
4	089015001013	Screw (M8 x 35 mm).....	1	31	089037007011	Screw w/External Washer (M5 x 20 mm).....	1
5	414011033	Spring Pin	2	32	411071001	Lock Nut (M6)	1
6	089040003002	Table Locking Lever.....	2	33	089037007012	Pull Rod	1
7	0121010903	Lever Screw	2	34	089040003901	Scale Label	1
8	0121010214	Outfeed Rod Primary Bracket.....	2	35	089037007013	Support Board	1
9	411071003	Lock Nut (M5)	2	36	089037007014	Mount Bracket	1
10	410171706	Screw (#10-24 x 1/2 in.).....	4	37	089037007015	Bolt (M6 x 15.5 mm)	2
11	089037007007	Screw (M4, Pan Hd.).....	2	38	089037007016	Motor Bracket.....	1
12	089037007006	Push Stick.....	1	39	0101010905	Spacer (D9.5 x 68 mm)	2
13	089037011022	Handle Bracket	2	40	080015001437	Bolt (1/4-20 x 3/4 in., Hex Hd.).....	2
14	410171722	Screw (#10-24 x 3/8 in., Pan Hd.).....	8	41	080015001436	Screw (M6 x 18 mm).....	3
15	0121010237	End Cap, Extension Table Rod	1	42	411062701	Hex Nut (1/4-20)	2
16	089040003003	Scale Indicator.....	1	43	080015001458	Spring Pin (D8 x 90 mm).....	1
17	410602002	Screw (M4 x 25 mm, Pan Hd.).....	1	44	089037007029	C-Ring.....	1
18	412042002	External Tooth Lock Washer	5	45	411062701	Hex Nut (1/4-20)	4
19	410132057	Screw (M4 x 8 mm, Pan Hd.).....	2	46	080015001439	Middle Bracket.....	1
20	089040003704	Miter Gauge Assembly	1	47	089037011047	Washer (D6.5 x D13 x 0.5t)	1
21	089037007009	Rod	1	48	089037007033	Block.....	1
22	410341006	Screw w/Washer (M6 x 12 mm, Hex Soc. Hd.)	2	49	089037007034	Hex Nut (3/8-16)	2
23	0121010313	Pivot Bracket Plate	2	50	089037007035	Carriage Bolt (1/4-20 x 42 mm)	1
24	0121010901	Eccentric Roller.....	1	51	089037007036	Work Plate.....	1
25	0121010314	Adjusting Plate.....	1	52	089110101033	Washer (D6.5 x D16 x 1t)	1
26	410371002	Screw w/Washer (M6 x 15 mm, Hex Hd.).....	2	53	080015001455	Hex Nut (1/4-20)	1
27	414011001	Spring Pin (M4 x 13 mm)	2	54	089037011048	Washer (D6.5 x D20 x 2.5t)	2
				55	089110101066	Screw w/Washer (M4 x 12 mm, Pan Hd.).....	1

RYOBI 10 in. TABLE SAW – MODEL NUMBER RTS21G

The model number will be found on a label attached to the cabinet. Always mention the model number in all correspondence regarding your **10 in. PORTABLE TABLE SAW** or when ordering parts.

PARTS LIST FOR FIGURE A

KEY NO.	PART NUMBER	DESCRIPTION	QTY	KEY NO.	PART NUMBER	DESCRIPTION	QTY
56	089037007032	Indicator.....	1	81	089037007022	Screw (M6 x 20 mm, Hex Hd.).....	2
57	089037011013	Indicator Bracket	1	82	089037007023	Mounting Bracket	1
58	411061001	Toothed Hex Nut (M6).....	4	83	089037007702	Riving Knife.....	1
59	410192001	Screw (M4 x 10 mm, Pan Hd.).....	3	84	089037011030	Clamping Bracket	1
60	089037007031	Screw (M4 x 10 mm, Hex Hd.).....	1	85	089037011031	Spring	1
61	0101010920	Arbor Nut	1	86	089037007709	Lever Assembly	1
62	0101010302	Outer Blade Washer.....	1	87	089037007700	Blade Guard Assembly (Inc. Key Nos. 95-100)	1
63	422010025	Saw Blade.....	1	88	089037007701	Anti-Kickback Pawls Assembly	1
64	089037007017	Screw (M4 x 0.7 mm).....	3	89	089037011018	Rear Support	1
65	411071001	Lock Nut (M6)	3	90	089037011019	Rear Rod.....	2
66	089037007018	Screw (M6 x 15 mm).....	1	91	089037011014	Extension Table.....	1
67	089037007019	Lever	1	92	089037011005	Saw Table	1
68	089037011027	Screw (M5 x 25 mm).....	4	93	089037011020	Outfeed Support Bracket.....	2
69	089037007020	Clamp Lock.....	1	94	089037011704	Rip Fence Assembly (See Figure C)	1
70	089037007021	Clamp	1	95	089037007910	Front Blade Guard Warning Label (Left)	1
71	089037007097	Plate.....	1	96	089037007909	Front Blade Guard Warning Label (Right)	1
72	089037007098	Bracket	1	97	089110113913	No Hands Warning Label.....	2
73	412011007	Washer (D5 x D12 x 1.5t).....	2	98	089037007912	Guard Warning Label (Left)	1
74	412021005	Lock Washer (M5).....	2	99	089037007911	Guard Warning Label (Right).....	1
75	089037007101	Screw (M5 x 10 mm, Button Soc. Hd.).....	2	100	089037007908	Warning Label (Upper Barrier)	1
76	089037011709	Motor Assembly.....	1				
77	412011701	Washer (D1/4 in. x D16 x 1t).....	2		Not Shown:		
78	410551701	Screw w/Washer (1/4-20 x 1/2 in., Pan Hd.)....	2		089037011021	Dado Throat Plate (Optional)	1
79	089037011053	Extension Rod (Front)	1		988000930	Operator's Manual (089037011908)	
80	089037011054	Extension Rod (Rear)	1		12-19-17 (Rev:03)		

RYOBI 10 in. TABLE SAW – MODEL NUMBER RTS21G

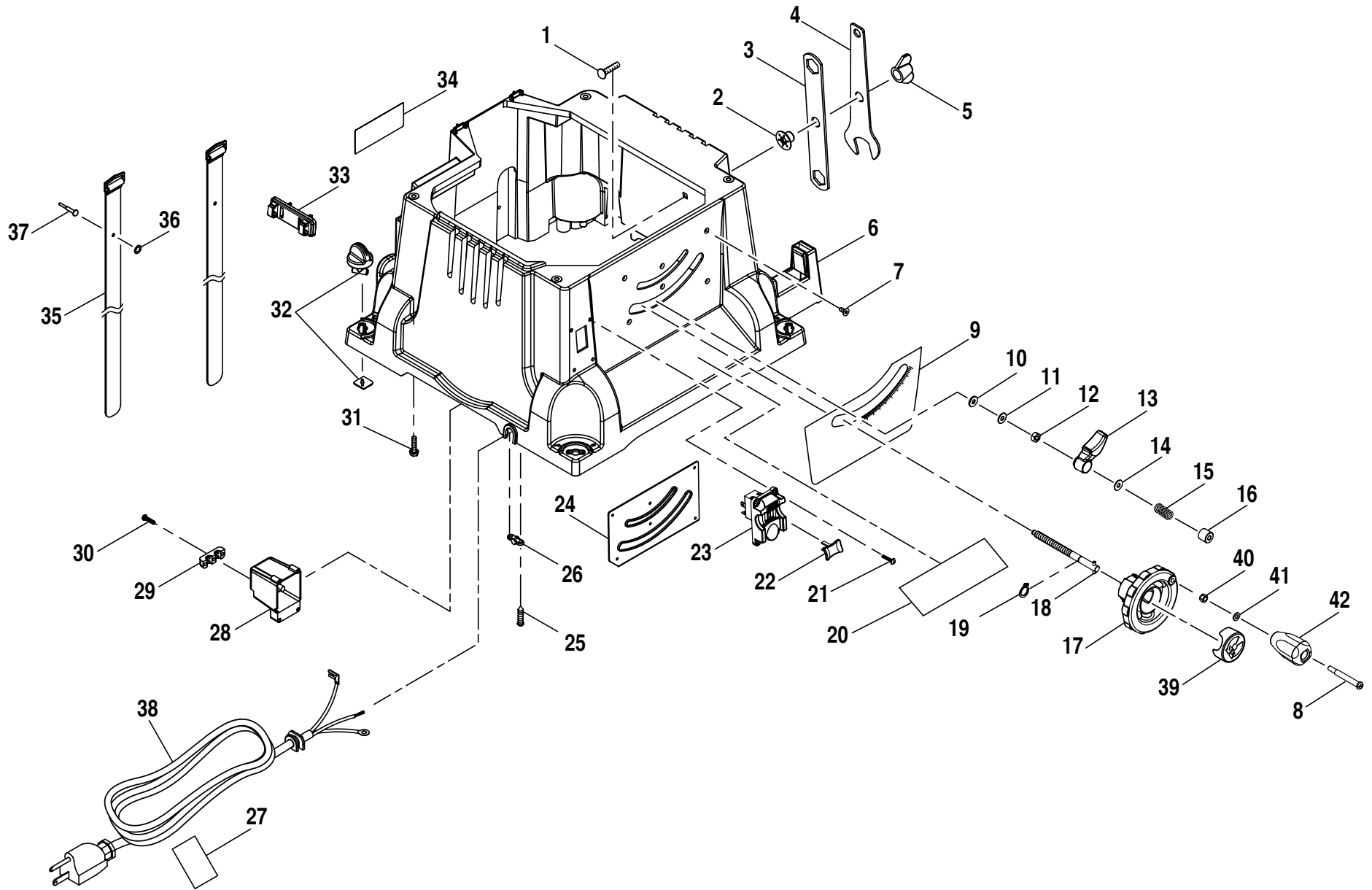

FIGURE B

RYOBI 10 in. TABLE SAW – MODEL NUMBER RTS21G

The model number will be found on a label attached to the cabinet. Always mention the model number in all correspondence regarding your **10 in. PORTABLE TABLE SAW** or when ordering parts.

PARTS LIST FOR FIGURE B

KEY NO.	PART NUMBER	DESCRIPTION	QTY	KEY NO.	PART NUMBER	DESCRIPTION	QTY
1	410031710	Carriage Bolt (5/16-18 x 1-1/2 in.).....	1	22	984406003	Switch Key.....	1
2	0134010238	Knob Ring.....	1	23	089110109712	Switch Assembly (Inc. Key No. 22).....	1
3	0101010312	Blade Wrench.....	1	24	089037007044	Plate.....	1
4	0101010313	Blade Wrench.....	1	25	410192002	Screw (M4 x 16 mm, Pan Hd.).....	2
5	089040003004	Wing Nut.....	1	26	0101040203	Cord Clamp.....	1
6	089040003703	Cabinet Assembly (Inc Key Nos. 9, 20, and 35).....	1	27	089037007902	Warning Label (French).....	1
7	080015001473	Screw (M4 x 7 mm, Flat Hd.).....	6	28	089037007046	Switch Box.....	1
8	0101140203	Handwheel Knob Screw.....	1	29	0131010210	Cord Clamp.....	1
9	089040003904	Front Panel Label.....	1	30	0000120817	Screw (#8 x 19.05 mm, Pan Hd.).....	3
10	080015001475	Plastic Washer (D7 x D19 x 2t).....	1	31	410161010	Screw (M6 x 25 mm, Cheese Hd.).....	4
11	089037007102	Washer (D6.5 x D20 x 1.6t).....	1	32	089040003702	Stand Knob and Gasket Assembly.....	4
12	080015001455	Hex Nut (1/4-20).....	1	33	089037011008	Miter Gauge Storage.....	1
13	089040003007	Lock Lever.....	1	34	089040003903	Data Label.....	1
14	089110101033	Washer (D1/4 in. x D16 x 1t).....	1	35	0121015002	Stand Strap.....	2
15	0101140904	Spring.....	1	36	412011109	Washer (D5.2 x D24 x 2t).....	2
16	089040003011	Knob.....	1	37	416090001	Rivet.....	2
17	0134010221	Handwheel.....	1	38	089037011707	Power Cord Assembly (Inc. Key No. 27).....	1
18	089037011024	Elevating Shaft.....	1	39	089040003010	Handwheel Cap.....	1
19	089037011023	E-Ring.....	1	40	411072702	Lock Nut (1/4-20).....	1
20	089040003902	Front Panel Warning Label.....	1	41	412012041	Washer (D6.5 x D13 x 1.5t).....	1
21	410601004	Screw (M14 x 18 mm, Pan Hd.).....	4	42	0131020212	Handwheel Lever.....	1

RYOBI 10 in. TABLE SAW – MODEL NUMBER RTS21G

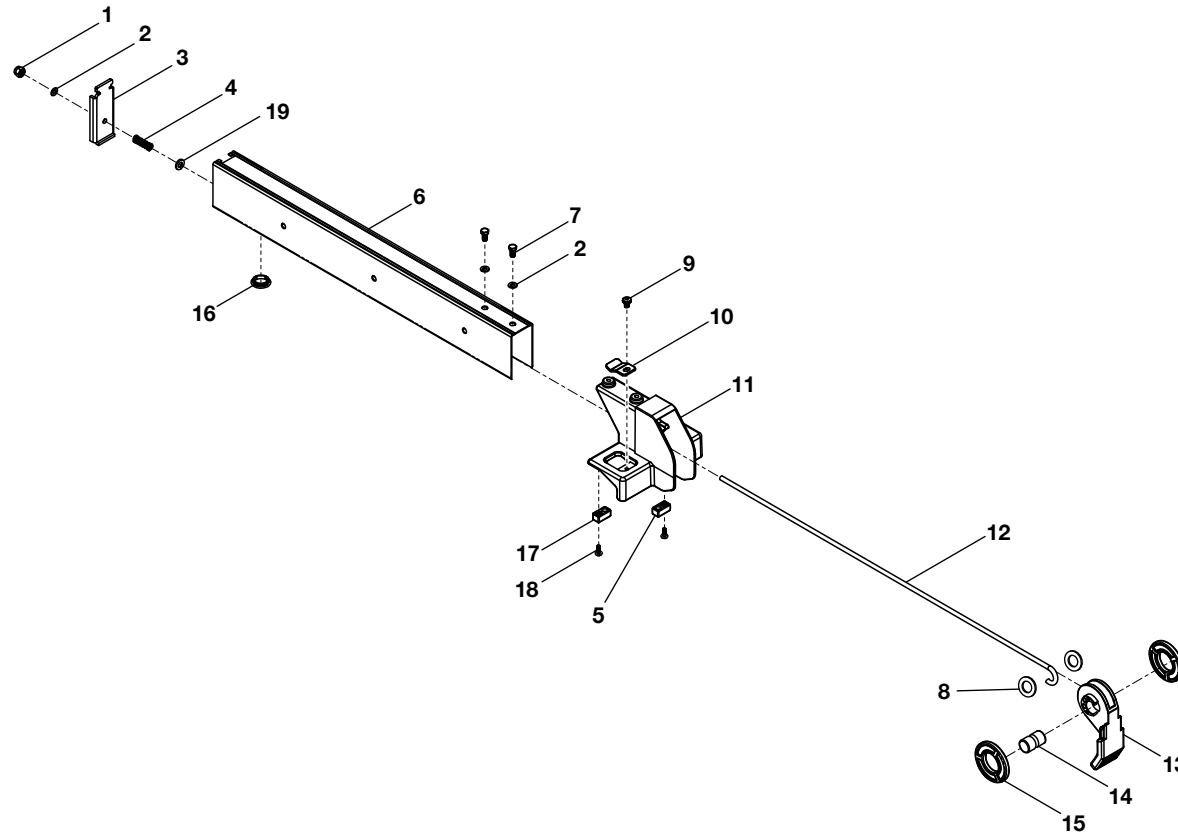

FIGURE C

KEY NO.	PART NUMBER	DESCRIPTION	QTY	KEY NO.	PART NUMBER	DESCRIPTION	QTY
1	411071001	Lock Nut (M6)	1	11	089040003008	Front Block	1
2	412011030	Washer (D6.5 x D16 x 1.5t)	3	12	089037011036	Rod	1
3	089037011032	Rear Clamping Plate.....	1	13	089040003009	Clamping Handle	1
4	0121010915	Compression Spring	1	14	0134010241	Axle	1
5	089037011039	Front Block Slider, right	1	15	0121010210	Ring Pad	2
6	089037011033	Rip Fence.....	1	16	0121010209	Rip Fence Slider	1
7	410051001	Screw (M6 x 15 mm, Hex Truss Hd.)	2	17	089037011038	Front Block Slider, left.....	1
8	412011115	Washer (D16 x D25 x 1.5t)	2	18	089037011040	Screw (8-32 x 8.5 mm, Flat Hd.).....	2
9	410541003	Screw (M4 x 10 mm, Pan Hd.).....	1	19	412011712	Washer (D1/4 x D13 x 1.5t).....	1
10	089037011034	Indicator.....	1		089040003704	Rip Fence Assembly (Inc. Key Nos. 1-18)	1

RYOBI 10 in. TABLE SAW – MODEL NUMBER RTS21G

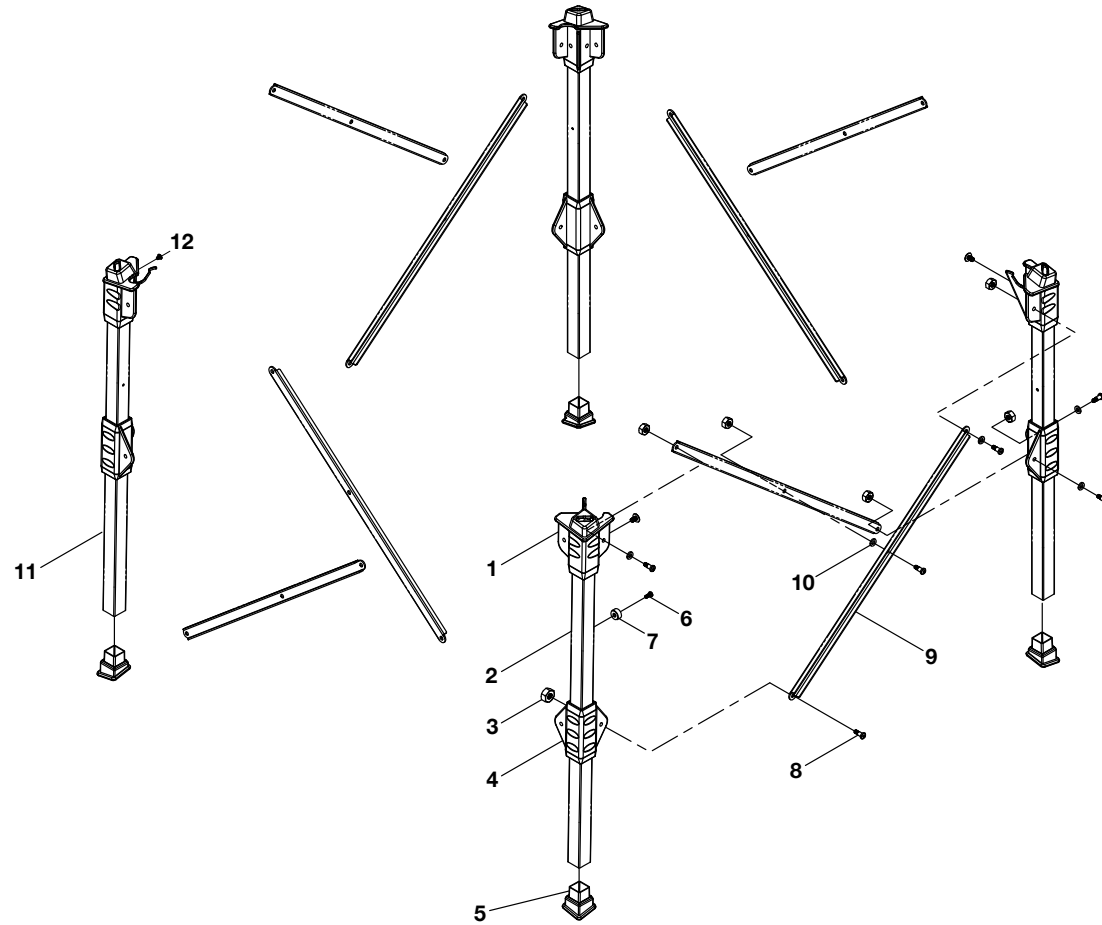
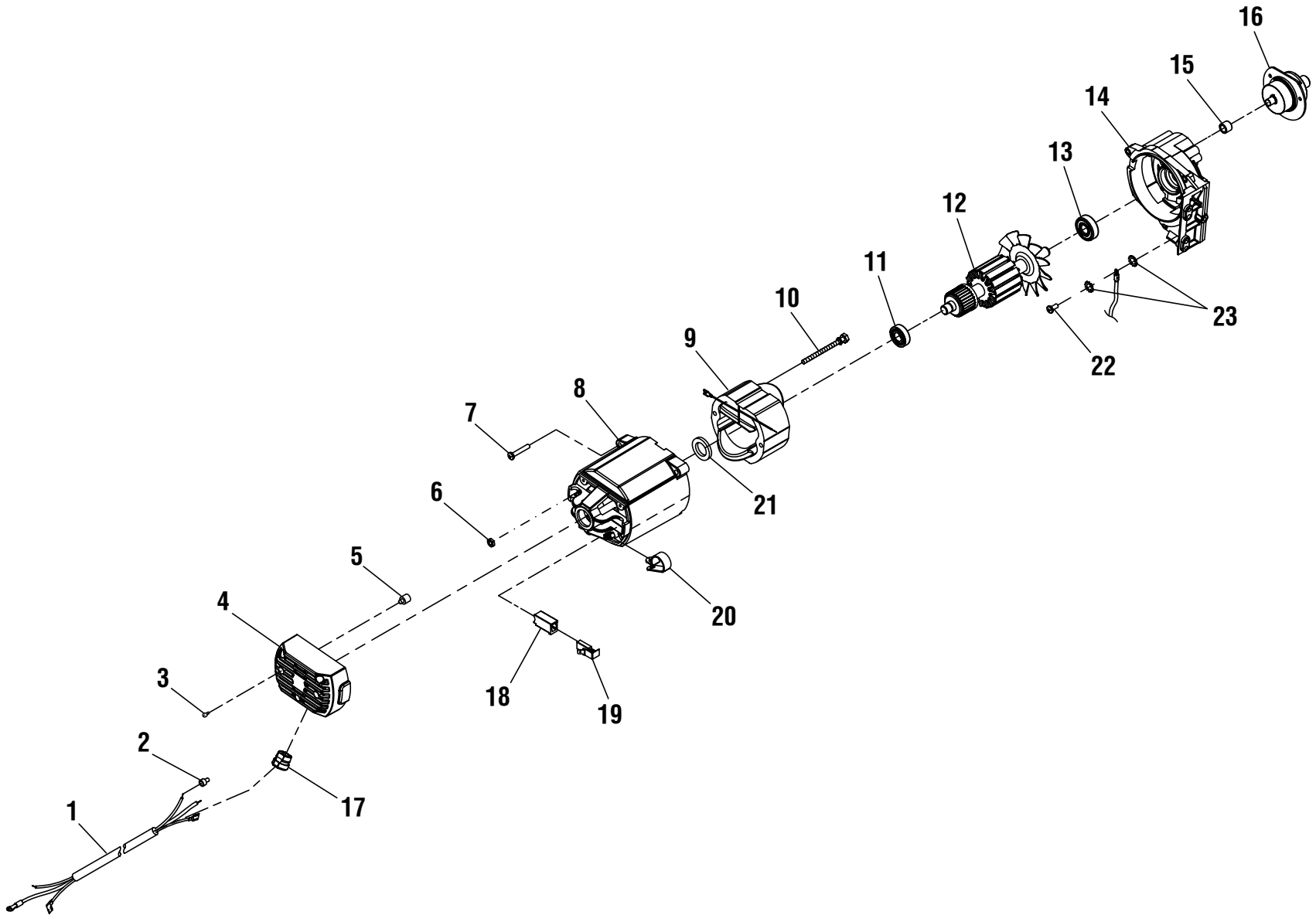

FIGURE D

KEY NO.	PART NUMBER	DESCRIPTION	QTY	KEY NO.	PART NUMBER	DESCRIPTION	QTY
1	089037011041	Connector Bracket.....	4	8	089037011043	Screw (M8 x 35 mm).....	20
2	089037011042	Leg.....	3	9	089037011045	Linkage	8
3	411071003	Lock Nut (M5)	20	10	089037011044	Linkage Ring.....	4
4	0121010205	Leg Adaptor.....	4	11	089037011046	Stationary Leg.....	1
5	0121010213	End Plug	4	12	410451016	Screw (M6 x 12 mm, Pan Hd.).....	4
6	410191003	Screw (M4 x 12 mm, Pan Hd.).....	1		089037011705	Leg Stand Assembly (Inc. Key Nos. 1-12).....	1
7	0121010228	Ring.....	1				

RYOBI 10 in. TABLE SAW – MODEL NUMBER RTS21G



SECTION "A"

RYOBI 10 in. TABLE SAW – MODEL NUMBER RTS21G

The model number will be found on a label attached to the cabinet. Always mention the model number in all correspondence regarding your **10 in. PORTABLE TABLE SAW** or when ordering parts.

PARTS LIST FOR SECTION “A”

KEY NO.	PART NUMBER	DESCRIPTION	QTY	KEY NO.	PART NUMBER	DESCRIPTION	QTY
1	089037007047	Motor Cord	1	13	089037007054	Ball Bearing (6201ZLU C3)	1
2	089037007048	Terminal.....	1	14	089037007055	Gear Box.....	1
3	410252001	Screw w/Washer (M4 x 12 mm, Pan Hd.).....	3	15	420110004	Needle Bearing (HK0910)	1
4	089037007049	Motor Rear Cap	1	16	089037011029	Arbor Assembly	1
5	0101010209	Brush Holder Clamp	2	17	451010003	Strain Relief.....	1
6	080015001427	Hex Nut (M5).....	2	18	089037007050	Brush Holder.....	2
7	089037011050	Screw w/Washer (M5 x 35 mm, Pan Hd.).....	3	19	0301025006	Brush	2
8	089037007051	Motor Housing.....	1	20	0121010242	Wire Clamp	1
9	089037011028	Field Assembly.....	1	21	412061001	Wave Washer	1
10	089037007052	Screw w/Washer (M5 x 70 mm, Hex Hd.).....	2	22	410174721	Screw (8#-32 x 3/8 in., Pan Hd.).....	1
11	089037007053	Ball Bearing (6001ZZ)	1	23	412042002	External Tooth Lock Washer (D4).....	2
12	089037011708	Armature Assembly (Inc. Key Nos 11 and 13).....	1				

RYOBI 10 in. TABLE SAW – MODEL NUMBER RTS21G

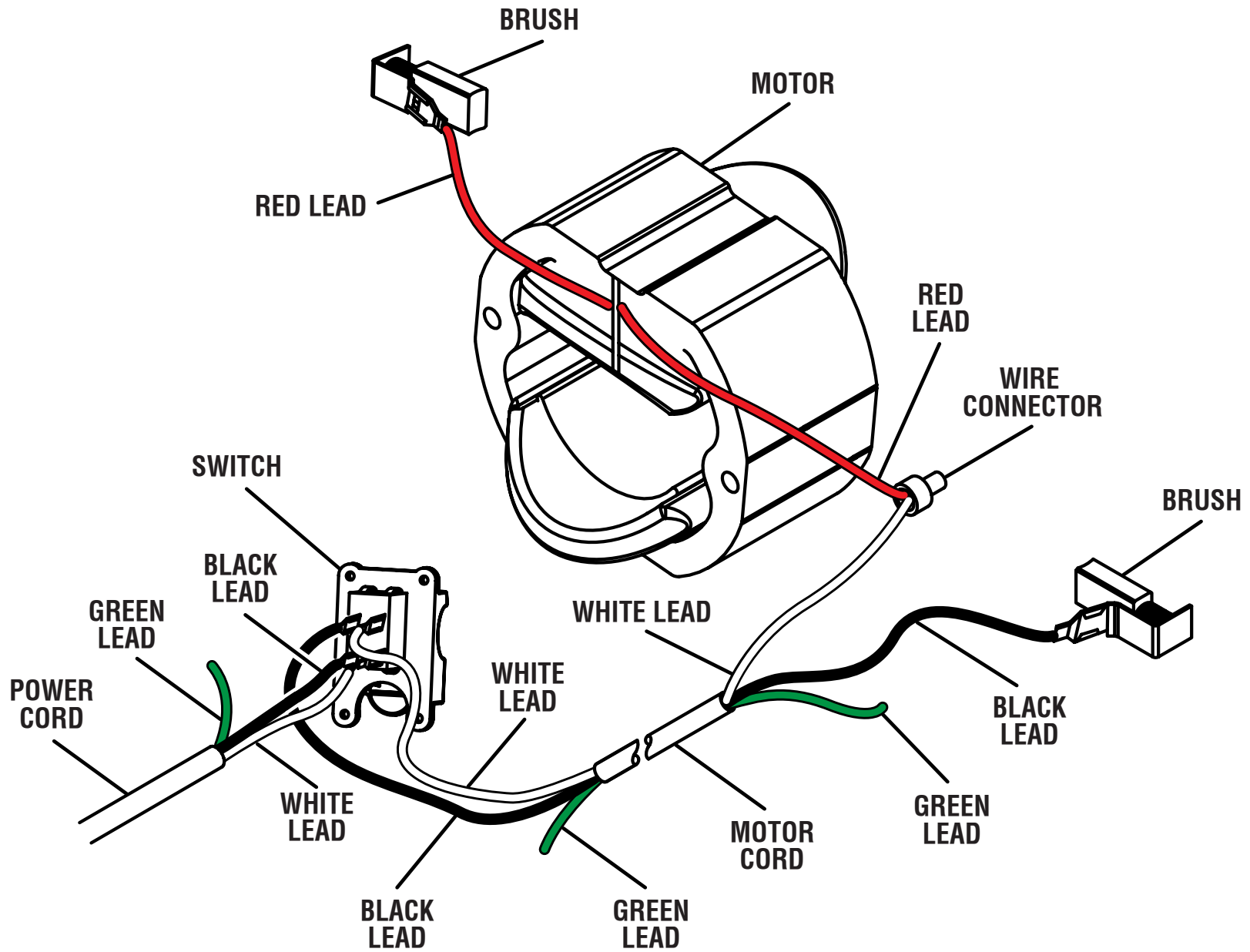

WIRING DIAGRAM