

REPAIR SHEET

BRAND

RYOBI

DESCRIPTION

MODEL NO.

PBLAG02

ONE+ HP Grinder w/ Paddle Switch

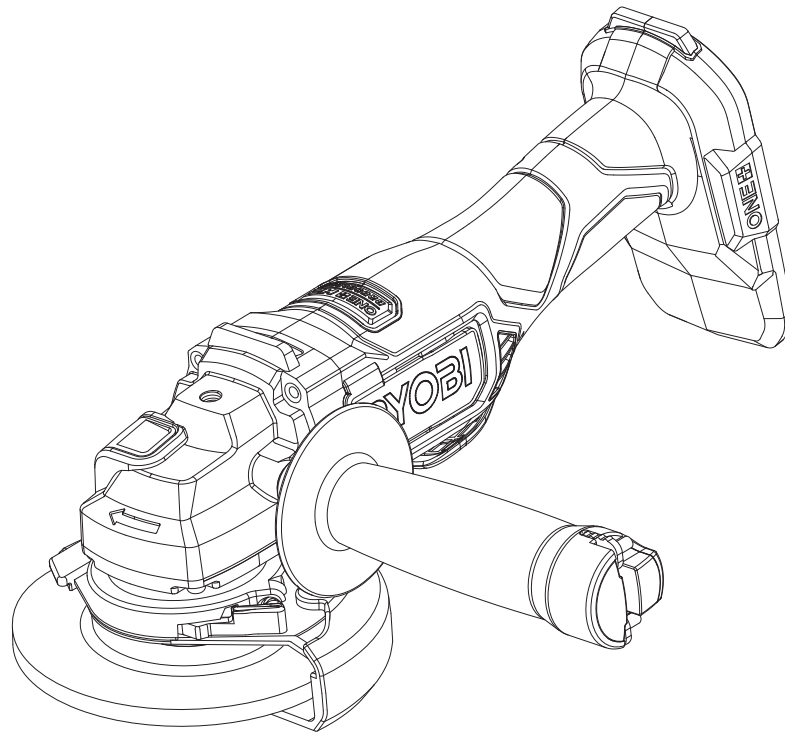

TTI CONSUMER POWER TOOLS, INC.

P.O. Box 1288, Anderson, SC 29622 ■ 1-800-525-2579 ■ www.ryobitools.com

5-2-24 (Rev:01)

The model number and manufacturing location will be found on a label attached to the product. Always mention this information in all communications regarding this product and when ordering parts.

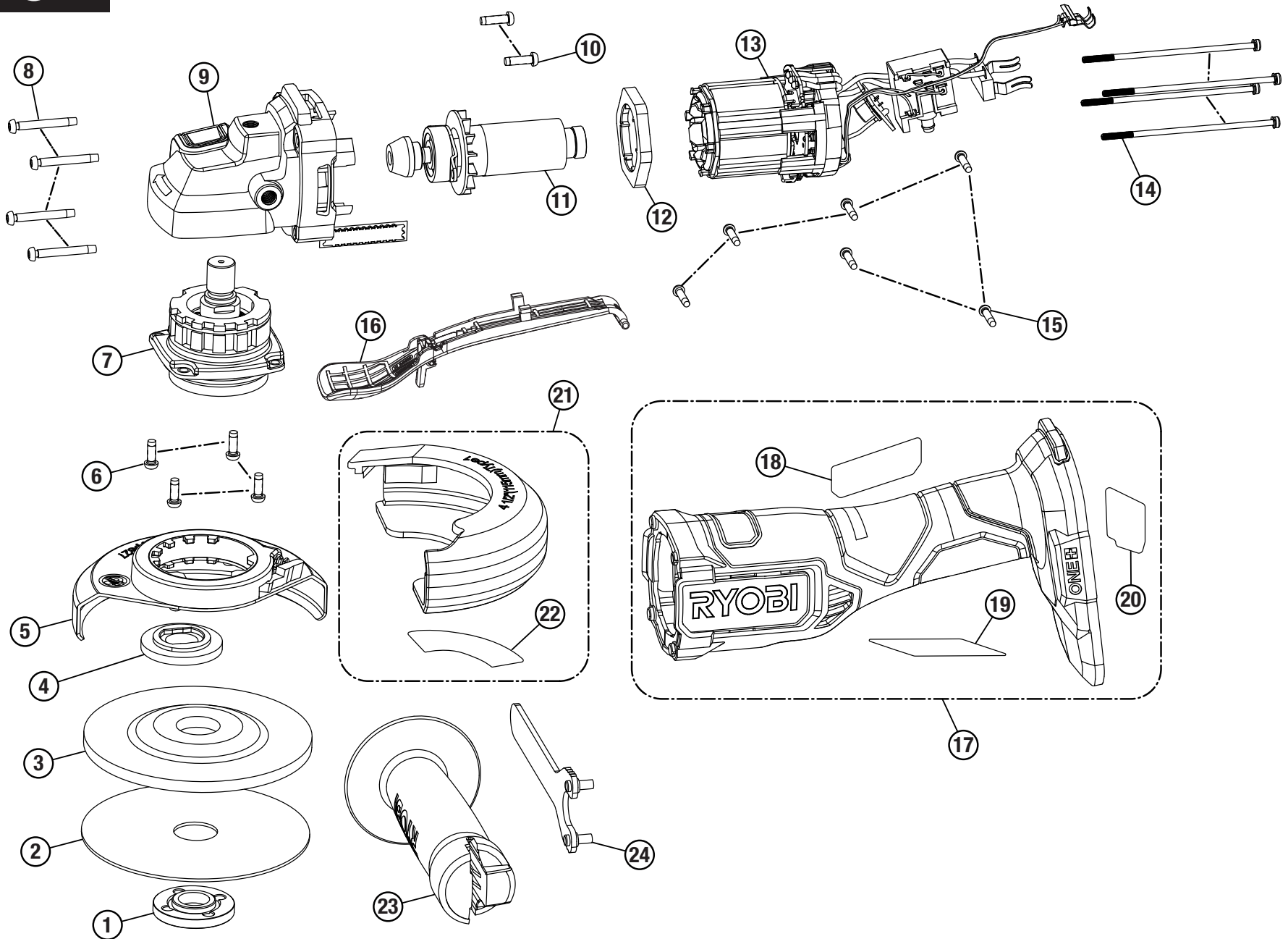



PBLAG02

PARTS LIST

KEY NO.	PART NO.	DESCRIPTION	QTY.
1	613556001	Flange Nut (5/8 in.)	1
2	903440003	Cutting Wheel	1
3	903440001	4.5 in. Grinder Wheel	1
4	613555006	Clamping Flange	1
5	204877018	Grinding Wheel Guard Assembly	1
6	660165011	Screw (M4 x 12 mm, T-20)	4
7	206692006	Output Shaft Assembly	1
8	660024067	Screw (M4 x 32 mm, T20 Pan Hd.)	4
9	206690015	Gear Case Assembly	1
10	661420001	Screw (M4 x 14 mm)	2
11	206691014	Motor Armature Assembly	1
12	531835001	Spacer	1
13	206689014	Field & Circuit Board Assembly	1

KEY NO.	PART NO.	DESCRIPTION	QTY.
14	662511008	Screw (M3.0 x 0.5-6G, Pan Hd.)	4
15	660031017	Screw (M3.5 x 16 mm, Torx. Pan Hd.)	6
16	204764019	Paddle Trigger & Button Assembly	1
17	204764020	Housing Assembly (Inc. Key Nos. 18-20)	1
18	941119256	Icon/Warning Label	1
19	941119257	Warning Label	1
20	941124581	Data Label	1
21	204772007	Cutting Guard w/ Label (Inc. Key No. 22)	1
22	941120755	Cutting Guard Icon Label	1
23	313309001	Auxiliary Handle	1
24	639701001	Spanner Wrench	1
	Not Shown:		
	999000345	Operator's Manual	

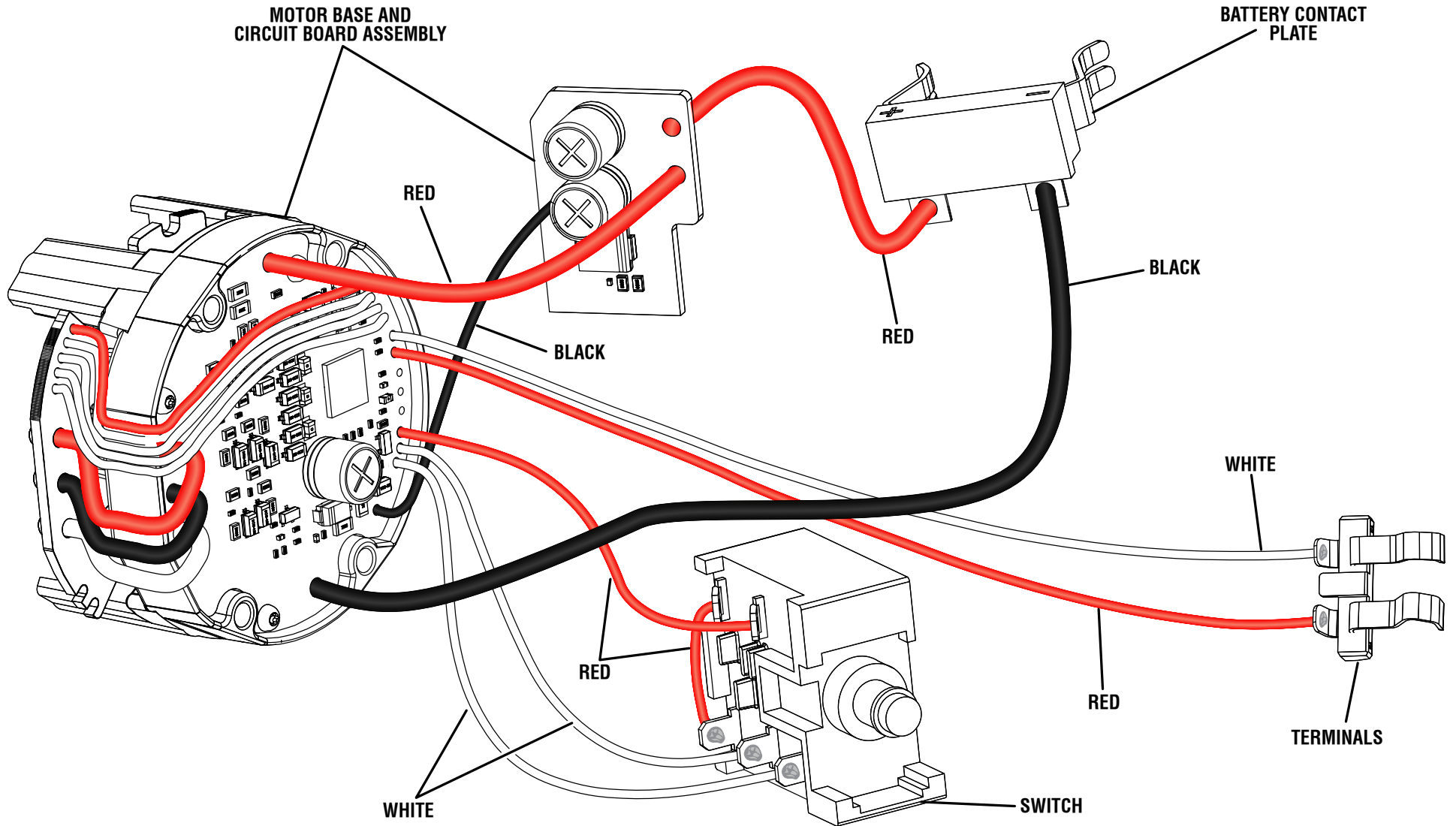

WIRING DIAGRAM