



OPERATOR'S MANUAL

18 VOLT INFLATOR

DIGITAL GAUGE

P730

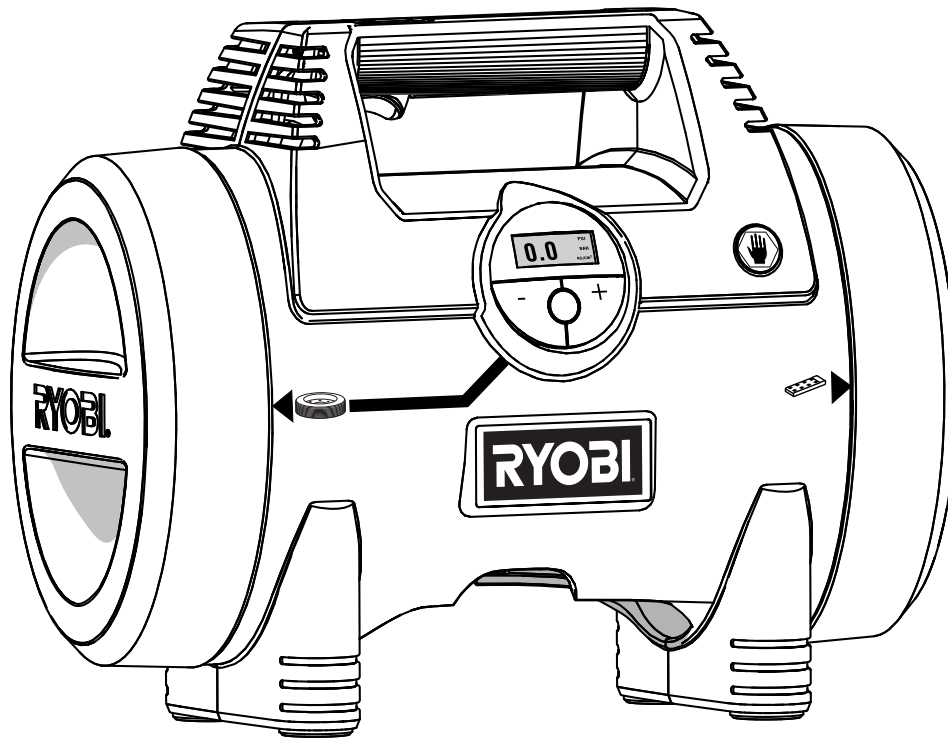

**BATTERIES AND
CHARGERS SOLD
SEPERATELY**

Your inflator has been engineered and manufactured to our high standard for dependability, ease of operation, and operator safety. When properly cared for, it will give you years of rugged, trouble-free performance.

⚠ WARNING: To reduce the risk of injury, the user must read and understand the operator's manual before using this product.

Thank you for your purchase.

SAVE THIS MANUAL FOR FUTURE REFERENCE

TABLE OF CONTENTS

■ Introduction	2
■ Warranty	2
■ General Safety Rules	3-4
■ Specific Safety Rules.....	4
■ Safety Rules for Charger	5
■ Symbols.....	6-7
■ Features.....	8
■ Assembly	9
■ Operation.....	9-14
■ Maintenance.....	15
■ Parts Ordering / Service	Back Page

INTRODUCTION

This tool has many features for making its use more pleasant and enjoyable. Safety, performance, and dependability have been given top priority in the design of this product making it easy to maintain and operate.

WARRANTY

RYOBI® POWER TOOL - LIMITED TWO YEAR WARRANTY AND 30 DAY EXCHANGE POLICY

One World Technologies, Inc., warrants its RYOBI® power tools with the following conditions:

30-DAY EXCHANGE POLICY: During the first 30 days after date of purchase, you may either request service under this warranty or you may exchange any RYOBI® power tool which does not work properly due to defective workmanship or materials by returning the power tool to the dealer from which it was purchased. To receive a replacement power tool or requested warranty service, you must present proof of purchase and return all original equipment packaged with the original product. The replacement power tool will be covered by the limited warranty for the balance of the two year period from the date of the original purchase.

WHAT THIS WARRANTY COVERS: This warranty covers all defects in workmanship or materials in your RYOBI® power tool for a period of two years from the date of purchase. With the exception of batteries, power tool accessories are warranted for ninety (90) days. Batteries are warranted for two years.

HOW TO GET SERVICE: Just return the power tool, properly packaged and postage prepaid, to an Authorized Service Center. You can obtain the location of the Service Center nearest you by contacting a service representative at One World Technologies, Inc., P.O. Box 1207, Anderson, SC 29622-1207, by calling 1-800-525-2579 or by logging on to www.ryobitools.com. When you request warranty service, you must also present proof of purchase documentation, which includes the date of purchase (for example, a bill of sale). We will repair any faulty workmanship, and either repair or replace any defective part, at our option. We will do so without any charge to you. We will complete the work in a reasonable time, but, in any case, within ninety (90) days or less.

WHAT'S NOT COVERED: This warranty applies only to the original purchaser at retail and may not be transferred. This warranty only covers defects arising under normal usage and does not cover any malfunction, failure or defects resulting from misuse, abuse, neglect, alteration, modification or repairs by other than Authorized Service Centers. One World Technologies, Inc. makes no warranties, representations or promises as to the quality or performance of its power tools other than those specifically stated in this warranty.

ADDITIONAL LIMITATIONS: Any implied warranties granted under state law, including warranties of merchantability or fitness for a particular purpose, are limited to two years from the date of purchase. One World Technologies, Inc. is not responsible for direct, indirect, or incidental damages, so the above limitations and exclusions may not apply to you. This warranty gives you specific legal rights, and you may also have other rights which vary from state to state.

GENERAL SAFETY RULES

WARNING!

READ AND UNDERSTAND ALL INSTRUCTIONS.

Failure to follow all instructions listed below, may result in electric shock, fire and/or serious personal injury.

SAVE THESE INSTRUCTIONS

WORK AREA

- **Keep your work area clean and well lit.** Cluttered benches and dark areas invite accidents.
- **Keep bystanders, children, and visitors away while operating an inflator.** Distractions can cause you to lose control.
- **Operate inflator in an open area at least 18 in. away from any wall or object that could restrict the flow of fresh air to ventilation openings.**

ELECTRICAL SAFETY

- **A battery operated tool with integral batteries or a separate battery pack must be recharged only with the specified charger for the battery.** A charger that may be suitable for one type of battery may create a risk of fire when used with another battery.
- **Use battery operated inflator only with specifically designated battery pack.** Use of any other batteries may create a risk of fire.
- **Use battery only with charger listed.**

MODEL	BATTERY PACK (P100)	CHARGER (P110)
P730	130255004 or 130224028	1423701, 140237021 or 140237023

PERSONAL SAFETY

- **Stay alert, watch what you are doing and use common sense when operating an inflator. Do not use inflator while tired or under the influence of drugs, alcohol, or medication.** A moment of inattention while operating inflator may result in serious personal injury.
- **Dress properly. Do not wear loose clothing or jewelry. Contain long hair. Keep your hair, clothing, and gloves away from moving parts.** Loose clothes, jewelry, or long hair can be caught in moving parts.
- **Avoid accidental starting. Be sure switch is in the locked or off position before inserting battery pack.** Carrying inflators with your finger on the switch or inserting the battery pack into an inflator with the switch on invites accidents.
- **Do not overreach. Keep proper footing and balance at all times.** Proper footing and balance enable better control of the inflator in unexpected situations.
- **Use safety equipment. Always wear eye protection.** Dust mask, non-skid safety shoes, hard hat, or hearing protection must be used for appropriate conditions.

- **Eye protection is required to guard against flying fasteners and debris which could cause severe eye injury.**
- **Do not wear loose clothing or jewelry. Contain long hair.** Loose clothes, jewelry, or long hair can be drawn into air vents.
- **Do not use on a ladder or unstable support.** Stable footing on a solid surface enables better control of the inflator in unexpected situations.

TOOL USE AND CARE

- **Do not force the tool. Use the correct tool for your application.** The correct tool will do the job better and safer at the rate for which it is designed.
- **Check hoses for weak or worn condition before each use, making certain all connections are secure.** Do not use if defect is found. Purchase a new hose or notify an authorized service center for examination or repair.
- **Release all pressures within the system slowly.** Dust and debris may be harmful.
- **Do not use inflator if switch does not turn it on or off.** An inflator that cannot be controlled with the switch is dangerous and must be repaired.
- **Disconnect battery pack from inflator or place the switch in the locked or off position before making any adjustments, changing accessories, or storing the inflator.** Such preventive safety measures reduce the risk of starting the inflator accidentally.
- **Store idle inflators out of reach of children and other untrained persons.** Inflators are dangerous in the hands of untrained users.
- **When battery pack is not in use, keep it away from other metal objects like: paper clips, coins, keys, nails, screws, or other small metal objects that can make a connection from one terminal to another.** Shorting the battery terminals together may cause sparks, burns, or a fire.
- **Check for misalignment or binding of moving parts, breakage of parts, and any other condition that may affect the inflator's operation. If damaged, have the inflator serviced before using.** Many accidents are caused by poorly maintained tools.
- **Use only accessories that are recommended by the manufacturer for your model.** Accessories that may be suitable for one inflator may create a risk of injury when used on another inflator.
- **Keep the inflator and its handle dry, clean and free from oil and grease.** Always use a clean cloth when cleaning. Never use brake fluids, gasoline, petroleum-based products, or any strong solvents to clean your inflator. Following this rule will reduce the risk of loss of control and deterioration of the enclosure plastic.

GENERAL SAFETY RULES

- **Never point any inflator toward yourself or others.**
- **Keep the exterior of the inflator dry, clean, and free from oil and grease.** Always use a clean cloth when cleaning. Never use brake fluids, gasoline, petroleum-based products, or any strong solvents to clean the unit. Following this rule will reduce the risk of deterioration of the enclosure plastic.
- **Do not exceed the pressure rating of any component in the system.**
- **Protect material lines and air lines from damage or puncture.** Keep hose and power cord away from sharp objects, chemical spills, oil, solvents, and wet floors.

SERVICE

- **Inflator service must be performed only by qualified repair personnel.** Service or maintenance performed by unqualified personnel may result in a risk of injury.
- **When servicing an inflator, use only identical replacement parts. Follow instructions in the Maintenance section of this manual.** Use of unauthorized parts or failure to follow Maintenance Instructions may create a risk of shock or injury.

SPECIFIC SAFETY RULES

- **Know your inflator.** Read operator's manual carefully. Learn its applications and limitations, as well as the specific potential hazards related to this tool. Following this rule will reduce the risk of electric shock, fire, or serious injury.
- **Risk of Bursting.** Do not preset inflator to result in output pressure greater than marked maximum pressure of item to be inflated. Do not use at pressure greater than 150 PSI.
- **To reduce the risk of electric shock,** do not expose to rain. Store indoors.
- **Inspect yearly for cracks, pin holes, or other imperfections that could cause inflator to become unsafe.** Never cut or drill holes in the inflator.
- **Make sure the hose is free of obstructions or snags.** Entangled or snarled hoses can cause loss of balance or footing and may become damaged.
- **Use the inflator only for its intended use. Do not alter or modify the unit from the original design or function.**
- **Always be aware that misuse and improper handling of this inflator can cause injury to yourself and others.**
- **Never leave a inflator unattended with the air hose attached.**
- **Do not continue to use a inflator or hose that leaks air or does not function properly.**
- **Always disconnect the air supply and power supply before making adjustments, servicing a inflator, or when an inflator is not in use.**
- **Do not attempt to pull or carry the inflator by the hoses.**
- **Always follow all safety rules recommended by the manufacturer of your inflator, in addition to all safety rules for the inflator.** Following this rule will reduce the risk of serious personal injury.
- **Do not use inflator as a breathing device.**
- **Never direct a jet of compressed air toward people or animals. Take care not to blow dust and dirt towards yourself or others.** Following this rule will reduce the risk of serious injury.
- **Protect your lungs.** Wear a face or dust mask if the operation is dusty. Following this rule will reduce the risk of serious personal injury.
- **Do not use this inflator to spray chemicals.** Your lungs can be damaged by inhaling toxic fumes.
- **Check damaged parts. Before further use of the inflator or air tool, a guard or other part that is damaged should be carefully checked to determine that it will operate properly and perform its intended function. Check for alignment of moving parts, binding of moving parts, breakage of parts, mounting, and any other conditions that may affect its operation. A guard or other part that is damaged should be properly repaired or replaced by an authorized service center.** Following this rule will reduce the risk of shock, fire, or serious injury.
- **Do not crush, drop or damage battery pack. Do not use a battery pack or charger that has been dropped or received a sharp blow.** A damaged battery is subject to explosion. Properly dispose of a dropped or damaged battery immediately.
- **Do not charge battery tool in a damp or wet location.** Following this rule will reduce the risk of electric shock.
- **Inspect tool cords periodically and, if damaged, have repaired at your nearest Authorized Service Center. Constantly stay aware of cord location.** Following this rule will reduce the risk of electric shock or fire.
- **Save these instructions.** Refer to them frequently and use them to instruct others who may use this inflator. If you loan someone this inflator, loan them these instructions also.

SAFETY RULES FOR CHARGER

WARNING!

READ AND UNDERSTAND ALL INSTRUCTIONS.

Failure to follow all instructions listed below, may result in electric shock, fire and/or serious personal injury.

- **Before using battery charger**, read all instructions and cautionary markings in this manual, on battery charger, battery, and product using battery to prevent misuse of the products and possible injury or damage.

CAUTION:

To reduce the risk of electric shock or damage to the charger and battery, charge only nickel-cadmium rechargeable batteries as specifically designated on your charger. Other types of batteries may burst, causing personal injury or damage.

- **Do not use charger outdoors or expose to wet or damp conditions.** Water entering charger will increase the risk of electric shock.
- **Use of an attachment not recommended or sold by the battery charger manufacturer may result in a risk of fire, electric shock, or injury to persons.** Following this rule will reduce the risk of electric shock, fire, or serious personal injury.
- **Do not abuse cord or charger.** Never use the cord to carry the charger. Do not pull the charger cord rather than the plug when disconnecting from receptacle. Damage to the cord or charger could occur and create an electric shock hazard. Replace damaged cords immediately.
- **Make sure cord is located so that it will not be stepped on, tripped over, come in contact with sharp edges or moving parts or otherwise subjected to damage or stress.** This will reduce the risk of accidental falls, which could cause injury, and damage to the cord, which could result in electric shock.
- **Keep cord and charger from heat to prevent damage to housing or internal parts.**
- **Do not let gasoline, oils, petroleum-based products, etc. come in contact with plastic parts.** They contain chemicals that can damage, weaken, or destroy plastic.

- **An extension cord should not be used unless absolutely necessary.** Use of improper extension cord could result in a risk of fire and electric shock. If extension cord must be used, make sure:

- a. That pins on plug of extension cord are the same number, size and shape as those of plug on charger.
- b. That extension cord is properly wired and in good electrical condition; and
- c. That wire size is large enough for AC ampere rating of charger as specified below:

Cord Length (Feet)	25'	50'	100'
Cord Size (AWG)	16	16	16

NOTE: AWG = American Wire Gauge

- **Do not operate charger with a damaged cord or plug**, which could cause shorting and electric shock. If damaged, have the charger replaced by an authorized serviceman.
- **Do not operate charger if it has received a sharp blow, been dropped, or otherwise damaged in any way.** Take it to an authorized serviceman for electrical check to determine if the charger is in good working order.
- **Do not disassemble charger.** Take it to an authorized serviceman when service or repair is required. Incorrect reassembly may result in a risk of electric shock or fire.
- **Unplug charger from outlet before attempting any maintenance or cleaning to reduce the risk of electric shock.**
- **Disconnect charger from the power supply when not in use.** This will reduce the risk of electric shock or damage to the charger if metal items should fall into the opening. It also will help prevent damage to the charger during a power surge.
- **Risk of electric shock.** Do not touch uninsulated portion of output connector or uninsulated battery terminal.
- **Save these instructions.** Refer to them frequently and use them to instruct others who may use this inflator. If you loan someone this inflator, loan them these instructions also to prevent misuse of the product and possible injury.

IMPORTANT SAFETY INSTRUCTIONS







1. SAVE THESE INSTRUCTIONS

This manual contains important safety and operating instructions for battery charger P110 (1423701, 140237021 or 140237023).

2. **Before using battery charger**, read all instructions and cautionary markings on battery charger, battery, and product using battery.
3. **CAUTION:** To reduce the risk of injury, charge only nickel-cadmium rechargeable batteries. Other types of batteries may burst, causing personal injury or damage.



SYMBOLS

Some of the following symbols may be used on this tool. Please study them and learn their meaning. Proper interpretation of these symbols will allow you to operate the tool better and safer.

SYMBOL	NAME	DESIGNATION/EXPLANATION
V	Volts	Voltage
A	Amperes	Current
Hz	Hertz	Frequency (cycles per second)
W	Watt	Power
min	Minutes	Time
~	Alternating Current	Type of current
≡	Direct Current	Type or a characteristic of current
n_0	No Load Speed	Rotational speed, at no load
	Class II Construction	Double-insulated construction
.../min	Per Minute	Revolutions, strokes, surface speed, orbits etc., per minute
	Wet Conditions Alert	Do not expose to rain or use in damp locations.
	Read The Operator's Manual	To reduce the risk of injury, user must read and understand operator's manual before using this product.
	Eye Protection	Always wear safety goggles or safety glasses with side shields and, as necessary, a full face shield when operating this product.
	Safety Alert	Precautions that involve your safety.
	Quick Shutoff	Depress the quick shutoff at any time to stop the inflator.
	Hot Surface	To reduce the risk of injury or damage, avoid contact with any hot surface.

SYMBOLS

The following signal words and meanings are intended to explain the levels of risk associated with this product.

SYMBOL	SIGNAL	MEANING
	DANGER:	Indicates an imminently hazardous situation, which, if not avoided, will result in death or serious injury.
	WARNING:	Indicates a potentially hazardous situation, which, if not avoided, could result in death or serious injury.
	CAUTION	Indicates a potentially hazardous situation, which, if not avoided, may result in minor or moderate injury.
	CAUTION	(Without Safety Alert Symbol) Indicates a situation that may result in property damage.

SERVICE

Servicing requires extreme care and knowledge and should be performed only by a qualified service technician. For service we suggest you return the product to the nearest **AUTHORIZED SERVICE CENTER** for repair. When servicing, use only identical replacement parts.

WARNING:

To avoid serious personal injury, do not attempt to use this product until you read thoroughly and understand completely the operator's manual. If you do not understand the warnings and instructions in the operator's manual, do not use this product. Call Ryobi customer service for assistance.

WARNING:



The operation of any power tool can result in foreign objects being thrown into your eyes, which can result in severe eye damage. Before beginning power tool operation, always wear safety goggles or safety glasses with side shields and, when needed, a full face shield. We recommend Wide Vision Safety Mask for use over eyeglasses or standard safety glasses with side shields. Always use eye protection which is marked to comply with ANSI Z87.1.

SAVE THESE INSTRUCTIONS

FEATURES

PRODUCT SPECIFICATIONS

Motor..... 18 Volt DC
High Pressure Hose Length 24 in.
Low Pressure Hose Length 14 in.
Gauges Digital Readout (PSI, KG/CM², and BAR)

Maximum Pressure..... 150 PSI, 10.34 BAR, 10.55 KG/CM²
Charger Input..... 120 V, 60 Hz, AC only
Charge Rate 1 hour

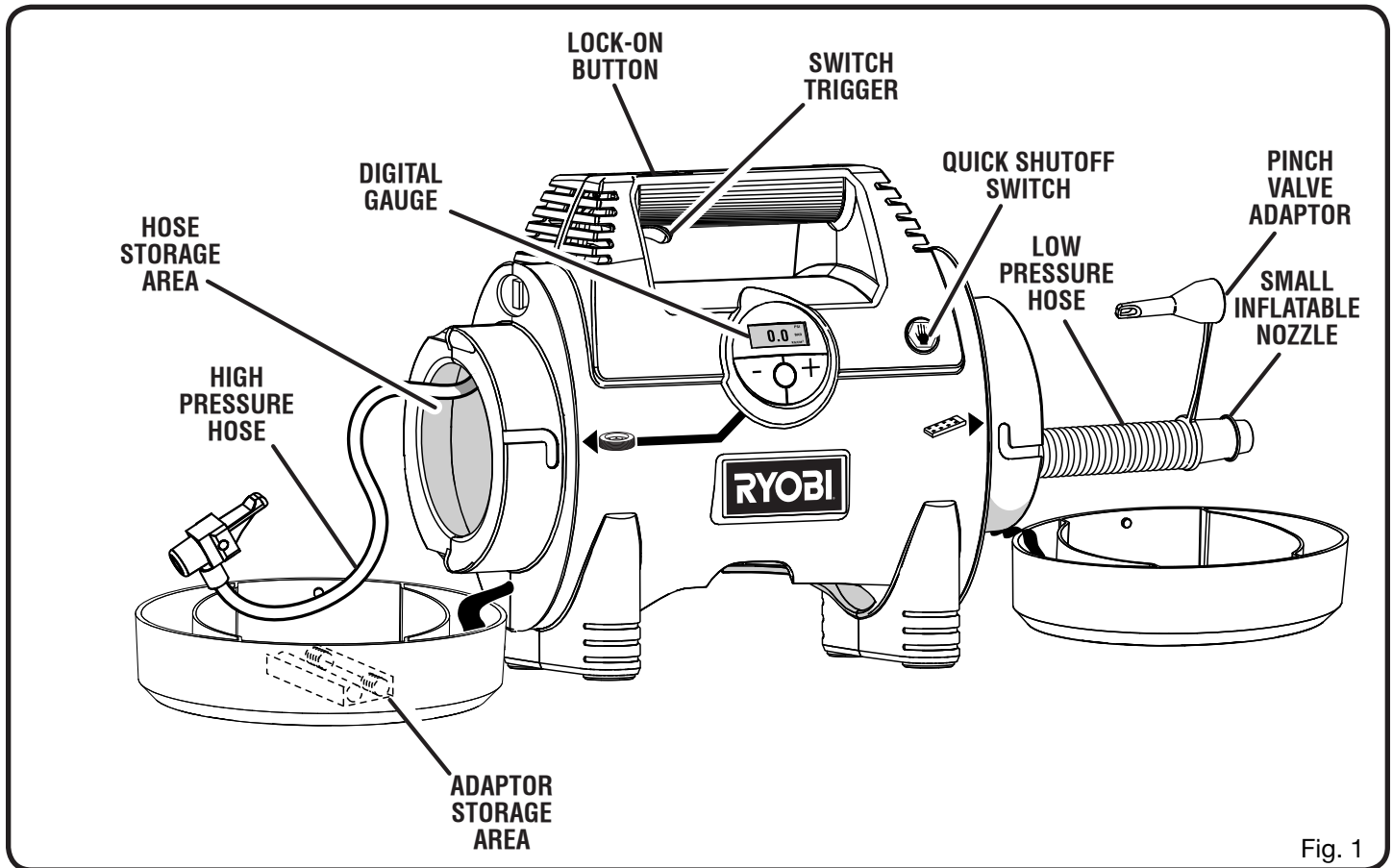

Fig. 1

KNOW YOUR INFLATOR

See Figure 1.

The safe use of this product requires an understanding of the information on the inflator and in this operator's manual as well as a knowledge of the project you are attempting. Before use of this product, familiarize yourself with all operating features and safety rules.

ADAPTOR STORAGE AREA

Adaptors provided with the inflator can be placed in the storage area, located inside the hose cover.

ADAPTORS

Adaptors provided with the inflator can be used in a variety of applications.

DIGITAL GAUGE

The digital gauge measures and displays air pressure, monitors pressure output, and is used to set pressure type.

HIGH PRESSURE HOSE

The high pressure hose can easily inflate high pressure items like motorcycle, car, and bicycle tires.

HOSE STORAGE AREA

The inflator has twin storage compartments located on each side of the inflator that allow easy storage of both hoses.

LOCK-ON BUTTON

The lock-on button is convenient for continuous inflating for extended periods of time.

LOW PRESSURE HOSE

The low pressure hose can easily inflate items such as air mattresses, rafts, floats, and other low pressure items requiring large quantities of air.

QUICK SHUTOFF SWITCH

The quick shutoff switch is a convenient shutoff switch that instantly stops the inflator during operation.

ASSEMBLY

UNPACKING

This product has been shipped completely assembled.

- Carefully remove the inflator and any accessories from the box. Make sure that all items listed in the packing list are included.
- Inspect the inflator carefully to make sure no breakage or damage occurred during shipping.
- Do not discard the packing material until you have carefully inspected and satisfactorily operated the inflator.
- If any parts are damaged or missing, please call 1-800-525-2579 for assistance.

PACKING LIST

18 Volt Inflator
Tapered Adaptor
Sport Ball Needle
Presta Valve Adaptor
Schrader Valve Removal Tool
Replacement Fuse
Operator's Manual

WARNING:

If any parts are damaged or missing do not operate this inflator until the parts are replaced. Failure to heed this warning could result in serious personal injury.

WARNING:

Do not attempt to modify this inflator or create accessories not recommended for use with this inflator. Any such alteration or modification is misuse and could result in a hazardous condition leading to possible serious personal injury.

WARNING:

To prevent accidental starting that could cause serious personal injury, always remove the battery pack from the inflator when assembling parts.

OPERATION

WARNING:

Do not allow familiarity with tools to make you careless. Remember that a careless fraction of a second is sufficient to inflict serious injury.

WARNING:

Always wear safety goggles or safety glasses with side shields when operating inflators. Failure to do so could result in objects being thrown into your eyes, resulting in possible serious injury.

WARNING:

Do not use any attachments or accessories not recommended by the manufacturer of this tool. The use of attachments or accessories not recommended can result in serious personal injury.

WARNING:

Do not leave items to be inflated unattended while inflator is in use. These items can burst and could cause serious injury.

CAUTION:

The inflator is not designed for continuous use. For every ten minutes of inflator use, ten minutes of cool down time when the inflator is not in use is required.

WARNING:

Since the pressure display is not calibrated, and is therefore not binding for exact values, tire pressure must be checked using a calibrated measuring device before driving a vehicle with vehicle tires inflated with the inflator. Driving a vehicle with improperly inflated tires could result in serious injury.

CAUTION:

The inflator is capable of inflating to 150 PSI, 10.34 BAR, or 10.55 Kg/Cm². To avoid over inflation, carefully follow instructions on items to be inflated. To avoid product damage, never exceed recommended pressures.

APPLICATIONS

You may use this inflator for the purpose listed below:

- Inflating air mattresses, sports balls, tires, floats, and toys

NOTE: The inflator is not designed for commercial application.

CAUTION:

If at any point during the charging process none of the LEDs are lit, remove the battery pack from the charger to avoid damaging the product. DO NOT insert another battery. Return the charger and battery to your nearest service center for service or replacement.

OPERATION

LED FUNCTIONS OF CHARGER LED WILL BE ON TO INDICATE STATUS OF CHARGER AND BATTERY PACK:

- Red LED on = Fast charging mode.
- Green LED on = Fully charged and in maintenance charge mode.
- Green LED on = When battery pack is inserted into charger, indicates hot battery pack or that battery pack is out of normal temperature range.
- Yellow and Green LEDs on = Deeply discharged or defective battery pack.
- No LED on = Defective charger or battery pack.

CHARGING THE BATTERY PACK

The battery pack for this inflator has been shipped in a low charge condition to prevent possible problems. Therefore, you should charge it until the green LED on the front of the charger comes on.

NOTE: Batteries will not reach full charge the first time they are charged. Allow several cycles (operation followed by recharging) for them to become fully charged.

CHARGING A COOL BATTERY PACK

If battery pack is within normal temperature range, the red LED on charger will come on.

NOTE: If the charger does not charge the battery pack under normal circumstances, return both the battery pack and charger to your nearest Authorized Service Center for electrical check.

- Charge the battery pack only with the charger provided.
- Make sure the power supply is normal household voltage, **120 volts, 60 Hz, AC only**.
- Connect the charger to the power supply.
- Place the battery pack in the charger aligning raised rib on the battery pack with the groove in the charger. See *Figure 3*.
- Press down on the battery pack to be sure contacts on the battery pack engage properly with contacts in the charger.
- Normally the red LED on charger will come on. This indicates the charger is in fast charging mode.
- Red LED should remain on for approximately 1 hour then the green LED will come on. Green LED on indicates battery pack is fully charged and charger is in maintenance charge mode.
NOTE: The green LED will remain on until the battery pack is removed from the charger or charger is disconnected from the power supply.
- If both yellow and green LEDs come on, this indicates a deeply discharged or defective battery pack. Allow the battery pack to remain in the charger for 15 to 30 minutes. When the battery pack reaches normal voltage range, the red LED should come on. If the red LED does not come on after 30 minutes, this may indicate a defective battery pack that should be replaced.
- After normal usage, a minimum of 1 hour of charging time is required to fully recharge battery pack.
- The battery pack will become slightly warm to the touch while charging. This is normal and does not indicate a problem.
- Do not place the charger and battery pack in an area of extreme heat or cold. They will work best at normal room temperature.

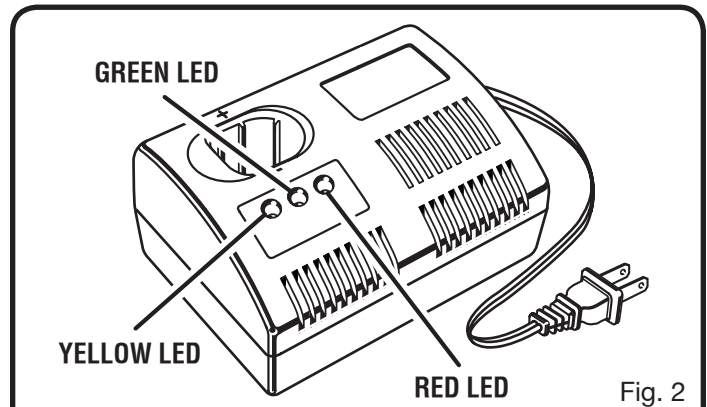

Fig. 2

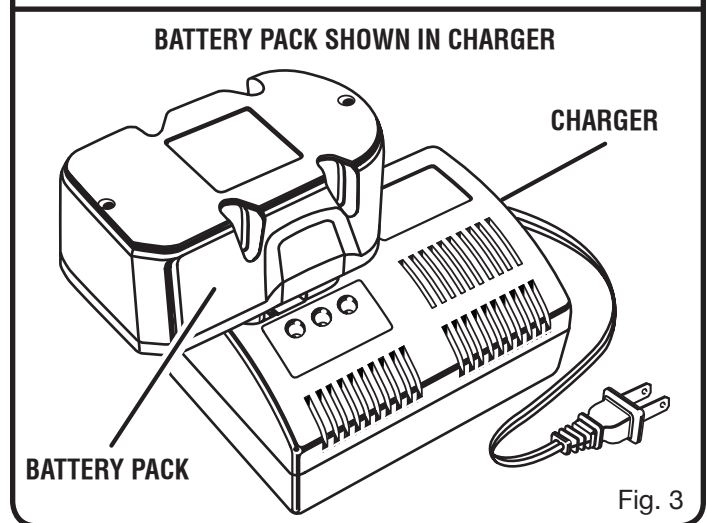

Fig. 3

NOTE: The charger and battery pack should be placed in a location where the temperature is more than 50°F but less than 100°F.

- When batteries become fully charged, unplug the charger from power supply and remove the battery pack.

CHARGING A HOT BATTERY PACK

When using the inflator continuously, the batteries in the battery pack will become hot. You should let a hot battery pack cool down for approximately 30 minutes before attempting to recharge. When the battery pack becomes discharged and is hot, this will cause the green LED to come on instead of the red LED. After 30 minutes, reinsert the battery pack in the charger. If the green LED continues to remain on, return battery pack to your nearest Authorized Service Center for checking or replacing.

NOTE: This situation only occurs when continuous use of the inflator causes the batteries to become hot. It does not occur under normal circumstances. Refer to **CHARGING A COOL BATTERY PACK** for normal recharging of batteries. If the charger does not charge your battery pack under normal circumstances, return both the battery pack and charger to your nearest Authorized Service Center for electrical check.

OPERATION

TO INSTALL BATTERY PACK

See Figure 4.

- Place the battery pack in the inflator. Align raised rib on battery pack with groove in the inflator's battery port.
- Make sure the latches on each side of the battery pack snap in place and that battery pack is secured in the inflator before beginning operation.

CAUTION:

When placing battery pack in the inflator, be sure raised rib on battery pack aligns with the inflator and latches into place properly. Improper installation of the battery pack can cause damage to internal components.

TO REMOVE BATTERY PACK

See Figure 4.

- Locate latches on side of battery pack and depress both sides to release battery pack.
- Remove battery pack from the inflator.

WARNING:

Improperly attached hoses or adaptors can become detached under pressure and cause serious injury. Possible air leaks can cause faulty pressure readings. Make sure all connections are tightly secured.

END CAP REMOVAL

See Figure 5.

To access the inflator hoses, the end caps must be removed. To remove the end caps, turn counterclockwise and remove. To replace endcap, push endcap tabs into slots on inflator and turn clockwise.

DUAL HOSES

See Figure 6.

The inflator has two hoses for two types of inflation. The high pressure hose is for inflating high pressure items like tires and sports balls. The low pressure hose is designed for inflating low pressure, high volume items like air rafts, mattresses, and floats.

NOTE: Pressure gauge and preset features are relative only to high pressure hose applications.

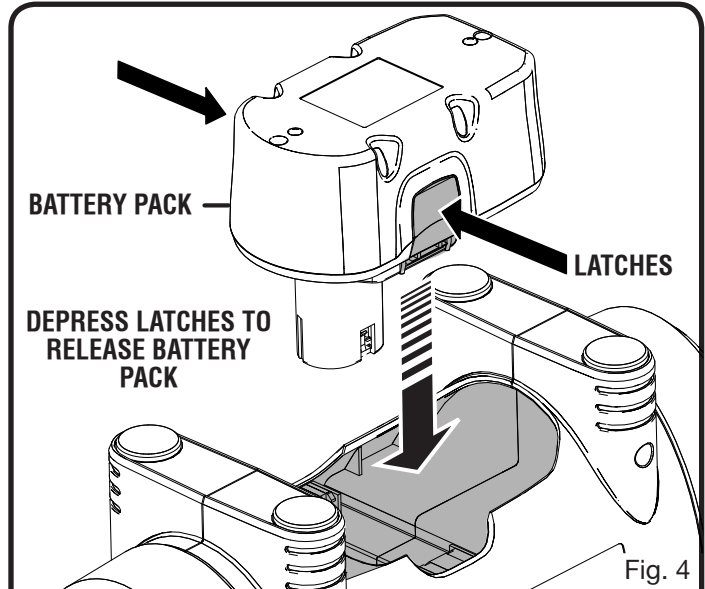

Fig. 4

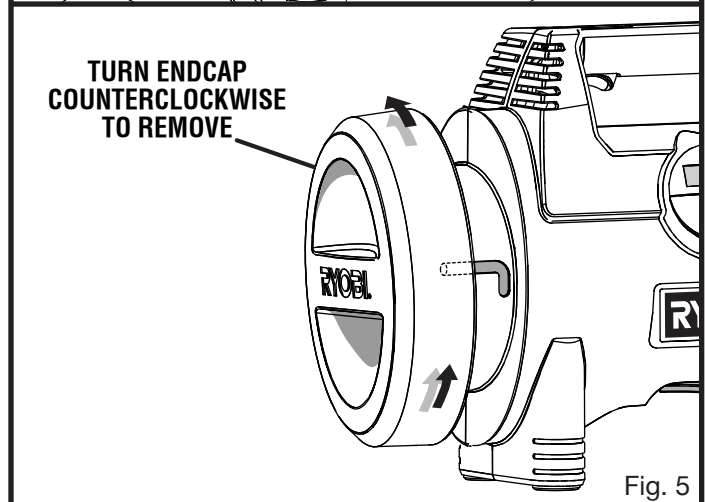

Fig. 5

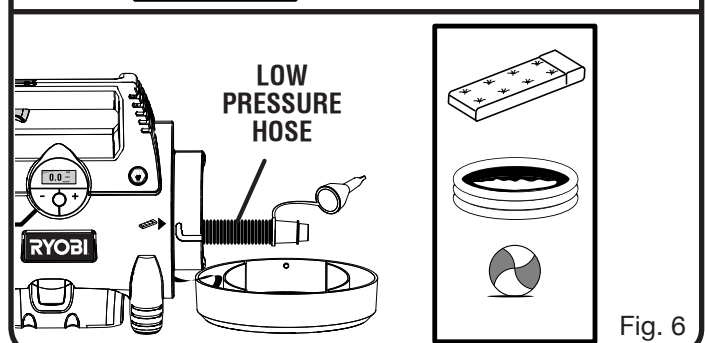
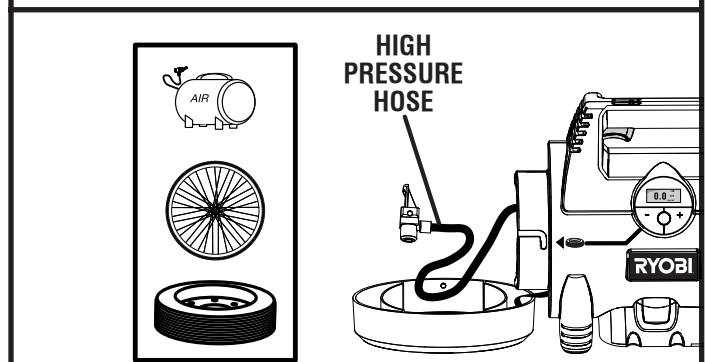

Fig. 6

OPERATION

SWITCH TRIGGER

See Figure 7.

To turn the inflator **ON**, depress the switch trigger. To turn it **OFF**, release the switch trigger.

LOCK-ON BUTTON

See Figure 7.

The inflator is equipped with a lock-on button for continuous inflating over extended periods of time. The lock-on button is located on top of the handle.

To lock-on:

- Depress the switch trigger.
- Push the lock-on button forward.
- Release the switch trigger and the inflator will continue running.
- To release the lock, depress the switch trigger again.

INFLATING WITH THE LOW PRESSURE AIR HOSE

See Figure 8.

The low pressure air hose is used to inflate low pressure items, such as air mattresses, pools, and floats.

A pinch valve adaptor comes as part of the small inflatable nozzle assembly that is attached to the end of the low pressure air hose. The pinch valve adaptor is used for items that have a smaller air opening or pinch valve.

- Insert pinch valve adaptor into pinch valve, insuring that the tip of the adaptor is inserted past the inner "flap" inside the valve. When inflating, ensure that the tip is not blocked during inflation.

CAUTION:

Always leave low pressure hose free of obstructions and with pinch valve adaptor off when not in use. Overheating could occur low pressure hose is blocked.

INFLATING WITH THE HIGH PRESSURE AIR HOSE

See Figure 9 - 10.

The air chuck on the high pressure air hose can be used without adaptors to inflate tires or with any application that has a valve stem that fits the air chuck opening.

- Position air chuck clamp in the unlock position perpendicular to the high pressure air hose.
- Place air chuck on valve stem.
- Push air chuck down so that the threaded section of the valve stem is inside the air chuck.
- Clamp the end of the air chuck down onto the valve stem by pressing air chuck clamp down until it stops or is parallel with the high pressure air hose.

NOTE: When inflating items of 10 PSI., .69 BAR, .70 KG/CM² or less, inflate in short bursts and check after each burst by feel or with a calibrated measuring device to determine accurate pressure.

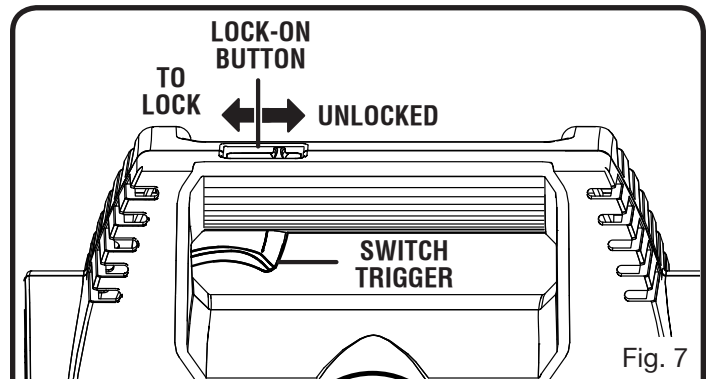

Fig. 7

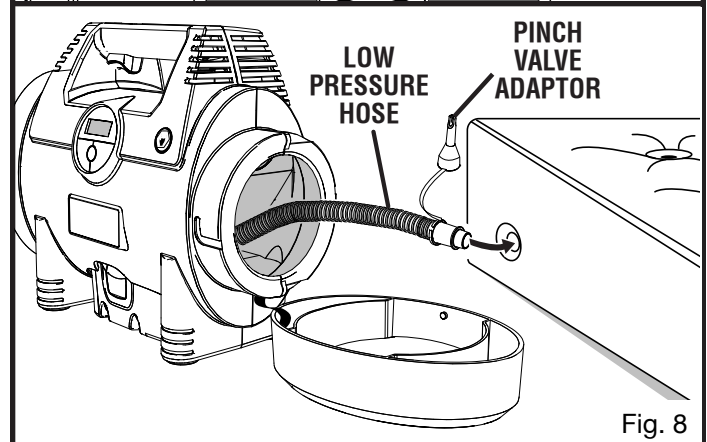

Fig. 8

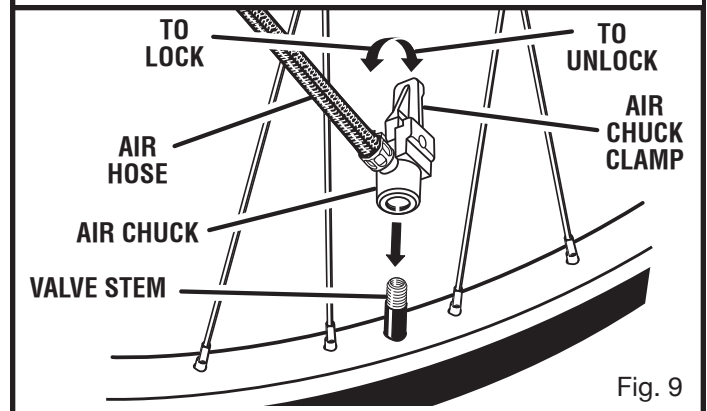

Fig. 9

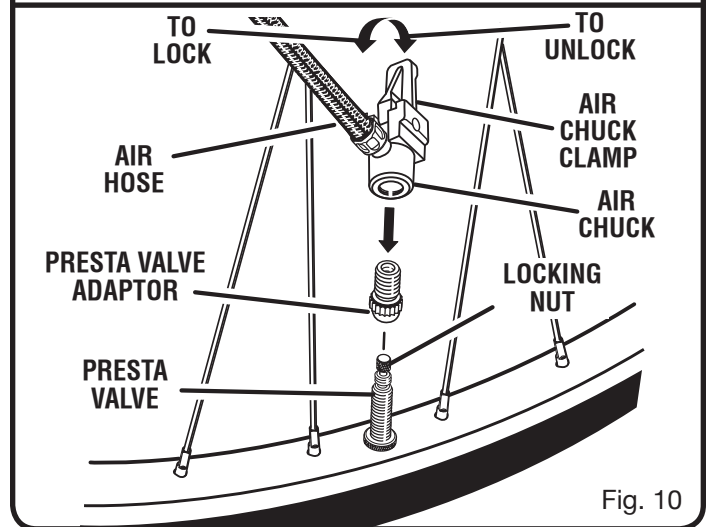

Fig. 10

OPERATION

INFLATING WITH THE HIGH PRESSURE AIR HOSE AND ADAPTORS

See Figure 10 - 13.

The high pressure air hose can be used with the provided adaptors to inflate a variety of items.

- Insert adaptor into air chuck and push air chuck clamp down until it locks into place.
- To remove, lift air chuck clamp up and remove adaptor from air chuck.

ADAPTORS

See Figures 10 - 12.

The supplied adaptors perform a variety of functions. The Schrader valve removal tool can be used to remove valve cores for quick deflation.

The tapered adaptor can be used on smaller pinch valves to inflate items like floats and children's toys, which usually require the user to inflate them by blowing air into them.

The sport ball needle can be used to inflate any type of sports ball or any other item that requires an inflation sport ball needle.

To use the sport ball needle:

- Insert sport ball needle into sports ball valve and inflate.
- Remove sport ball needle after inflation.

NOTE: Pressure required for most sports balls is too low for accurate reading on gauge.

The Presta valve adaptor can be used for Presta valve stems as described below. (See Figure 12) Before inflating a tire with a Presta valve, loosen the locking nut on the valve stem to inflate. Once inflation is complete, tighten the locking nut to seal the tire valve.

To use the Presta valve adaptor:

- Loosen Presta valve locking nut.
- Thread Presta valve adaptor onto valve stem with larger open end toward wheel.
- Position the air chuck clamp in the unlock position.
- Clamp the end of the air chuck down onto the Presta valve adaptor by pressing air chuck clamp down until it locks into place.
- After inflation, remove air chuck and tighten locking nut.

ADAPTOR STORAGE

See Figure 14.

When not in use, adaptors provided with the inflator can be placed in the removable storage cradle located on the inside cover of the inflator.

HOSE STORAGE

See Figure 14.

When not in use, the air hoses provided with the inflator can be placed in the storage areas located on both sides of the inflator.

NOTE: Do not store low pressure hose with pinch valve adaptor in place on small inflatable nozzle.

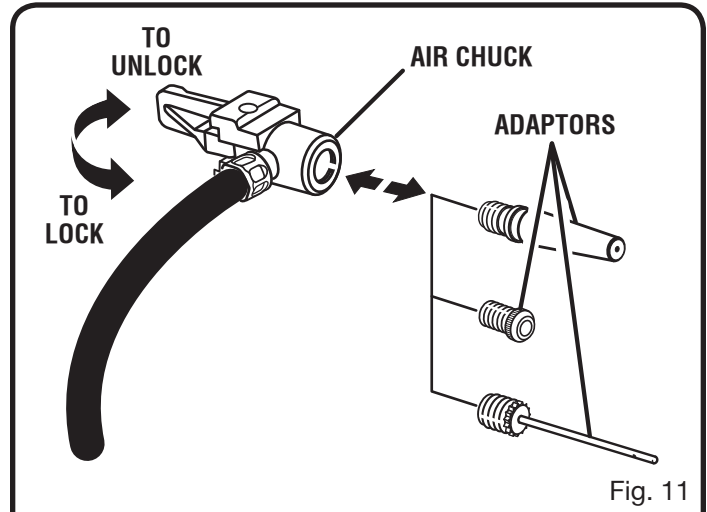

Fig. 11

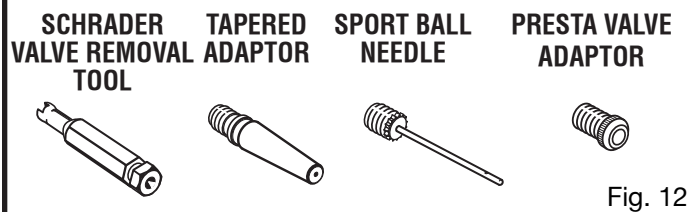

Fig. 12

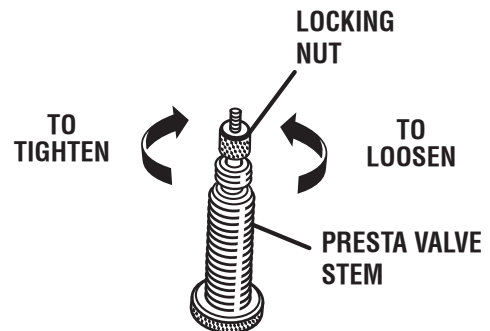

Fig. 13

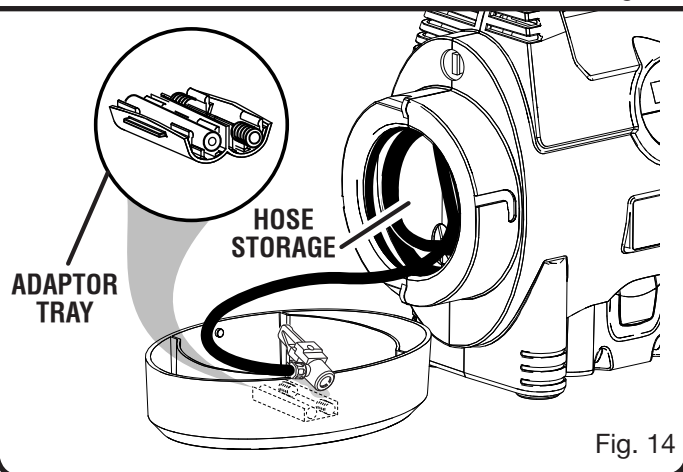

Fig. 14

OPERATION

QUICK SHUTOFF SWITCH

See Figure 15.

Depress the quick shutoff switch at any time to stop the inflator.

DIGITAL GAUGE

See Figures 15.

NOTE: Digital gauge displays pressure of high pressure hose only. Preset features apply to high pressure applications only.

The digital gauge on the inflator is multifunctional. It serves as a pressure gauge, monitors the amount of pressure being applied to the item being inflated, and can change air pressure measurement units from PSI to BAR to KG/CM².

To turn the digital gauge **ON**, press the **ON/RESET** button or depress the switch trigger.

NOTE: Make sure digital gauge is set at 0 before use. If gauge reads "Err" or needs resetting, press and hold **ON/RESET** button for 4-7 seconds.

NOTE: The digital gauge will automatically shut off when not in use for 2 and a half minutes or more.

To use the pressure gauge feature:

- Turn digital gauge on by pressing **ON/RESET** button or depressing and releasing switch trigger.
- Place air chuck over valve stem and lock in place. Readout will appear on gauge.

NOTE: The pressure readout on the gauge while inflating is a measurement of the fluctuating pressure between the item and the high pressure hose. To get an accurate reading, stop inflating and follow above instructions for reading the air pressure.

To switch from PSI, KG/CM², and BAR:

- With gauge **ON**, press and hold down **ON/RESET** button for at least 7 seconds.
- The current measuring unit will flash. Press the **ON/RESET** button again to select the desired measuring unit.
- The setting takes effect after the display stops flashing. (4-7 seconds)

NOTE: After preset pressure has been set, pressure setting stays in the gauge memory for 120 seconds. To recall the previous pressure setting for up to 120 seconds after inflation, press the (+) or (-) button.

To reset preset pressure, press and hold the **ON/RESET** button.

INFLATING MANUALLY FOR HIGH AND LOW PRESSURE APPLICATIONS

- Connect either high or low pressure hose to item to be inflated.
- Depress and hold switch trigger until desired pressure is reached.
- Release the switch trigger.

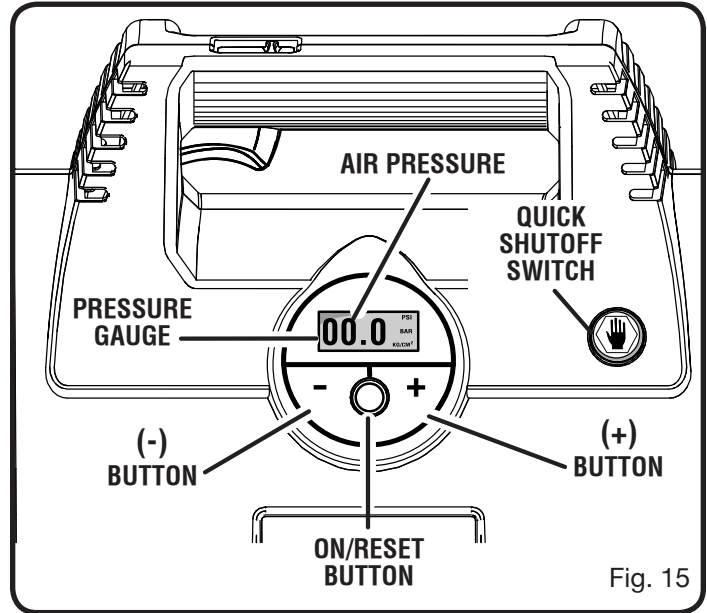

Fig. 15

INFLATING USING THE PRESET PRESSURES FEATURE WITH AUTOMATIC SHUTOFF

NOTE: Digital gauge displays pressure of high pressure hose only.

- With gauge **ON**, press and hold down (+) or (-) buttons to select desired shutoff pressure.

NOTE: Numbers will flash while setting pressure. Holding buttons down will make the pressure number increase/decrease faster.

- Depress switch trigger.
- Push the lock-on button forward.
- Release the switch trigger and the inflator will continue running.

NOTE: For preset pressures of 39 PSI, 2.68 BAR, or 2.74 KG/CM² or less, the unit will automatically stop just short of the preset pressure. Manually depress the switch trigger again to release the lock-on button and provide an additional short "burst" of air to achieve preset pressure.

For preset pressures of 40 PSI, 2.75 BAR, or 2.74 KG/CM, or greater, the unit will automatically stop at 40 PSI, 2.75 BAR, or 2.74 KG/CM regardless of preset pressure setting. This feature helps guard against over inflation and possible bursting. Manually depress the switch trigger again to release the lock-on button and continue inflating by holding the trigger in the **ON** position to achieve desired pressure. Shutoff will occur again just before target pressure is reached.

NOTE: Read actual pressure only when unit is not operating.

MAINTENANCE

⚠ WARNING:

When servicing, use only identical replacement parts. Use of any other parts may create a hazard or cause product damage.

⚠ WARNING:

Always wear safety goggles or safety glasses with side shields during inflator operation or when blowing dust. If operation is dusty, also wear a dust mask.

⚠ WARNING:

To avoid serious personal injury, always remove the battery pack from the inflator when cleaning or performing any maintenance.

GENERAL MAINTENANCE

Avoid using solvents when cleaning plastic parts. Most plastics are susceptible to damage from various types of commercial solvents and may be damaged by their use. Use clean cloths to remove dirt, dust, oil, grease, etc.

⚠ WARNING:

Do not at any time let brake fluids, gasoline, petroleum-based products, penetrating oils, etc., come in contact with plastic parts. Chemicals can damage, weaken or destroy plastic which may result in serious personal injury.

BATTERIES

The battery pack for this inflator is equipped with nickel-cadmium rechargeable batteries. Length of service from each charging will depend on the type of work you are doing.

The batteries in this inflator have been designed to provide maximum trouble-free life. However, like all batteries, they will eventually wear out. **Do not** disassemble battery pack and attempt to replace the batteries. Handling of these batteries, especially when wearing rings and jewelry, could result in a serious burn.

To obtain the longest possible battery life, we suggest the following:

- Remove the battery pack from the charger once it is fully charged and ready for use.

For battery storage longer than 30 days:

- Store the battery pack where the temperature is below 80°F.
- Store battery packs in a “discharged” condition.

Only the parts shown on the parts list are intended to be repaired or replaced by the customer. All other parts should be replaced at an Authorized Service Center.

REPLACEMENT FUSE

See Figure 16.

A fuse has been supplied with the inflator to replace the inflator fuse when needed.

- Remove battery pack from the inflator.
- Remove the current fuse and discard.
- A replacement fuse was supplied with the inflator. Use this fuse to replace the blown fuse.

NOTE: Use only 20 amp JAT blade type automotive fuses for replacement.

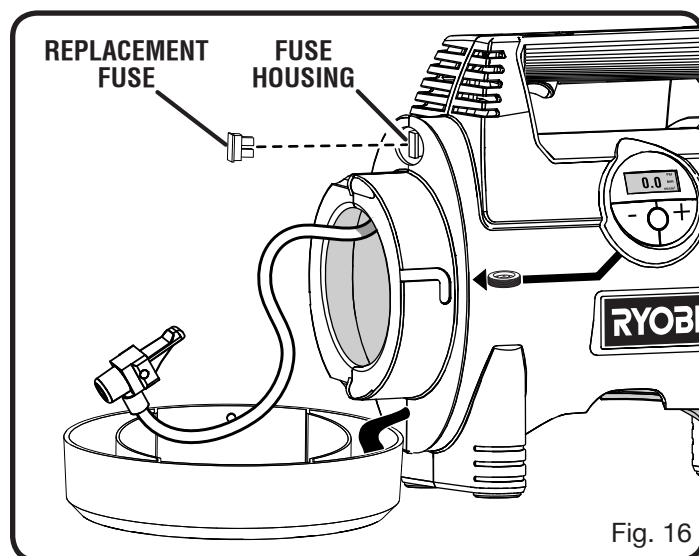

BATTERY PACK REMOVAL AND PREPARATION FOR RECYCLING



To preserve natural resources, please recycle or dispose of batteries properly.

This product contains nickel-cadmium batteries. Local, state or federal laws may prohibit disposal of nickel-cadmium batteries in ordinary trash.

Consult your local waste authority for information regarding available recycling and/or disposal options.

⚠ WARNING:

Upon removal, cover the battery pack's terminals with heavy-duty adhesive tape. Do not attempt to destroy or disassemble battery pack or remove any of its components. Nickel-cadmium batteries must be recycled or disposed of properly. Also, never touch both terminals with metal objects and/or body parts as short circuit may result. Keep away from children. Failure to comply with these warnings could result in fire and/or serious injury.



OPERATOR’S MANUAL

18 VOLT INFLATOR

DIGITAL GAUGE

P730

⚠ WARNING:

Some dust created by power sanding, sawing, grinding, drilling, and other construction activities contains chemicals known to cause cancer, birth defects or other reproductive harm. Some examples of these chemicals are:

- lead from lead-based paints,
- crystalline silica from bricks and cement and other masonry products, and
- arsenic and chromium from chemically-treated lumber.

Your risk from these exposures varies, depending on how often you do this type of work. To reduce your exposure to these chemicals: work in a well ventilated area, and work with approved safety equipment, such as those dust masks that are specially designed to filter out microscopic particles.

• **SERVICE**

Now that you have purchased your tool, should a need ever exist for repair parts or service, simply contact your nearest Authorized Service Center. Be sure to provide all pertinent facts when you call or visit. Please call 1-800-525-2579 for your nearest Authorized Service Center. You can also check our web site at www.ryobitools.com for a complete list of Authorized Service Centers.

• **MODEL NO. AND SERIAL NO.**

The model number of this tool will be found on a plate attached to the motor housing. Please record the model number and serial number in the space provided below.

• **HOW TO ORDER REPAIR PARTS**

When ordering repair parts, always give the following information:

- MODEL NUMBER P730
- SERIAL NUMBER

Ryobi® is a registered trademark of Ryobi Limited used under license.

ONE WORLD TECHNOLOGIES, INC.

1428 Pearman Dairy Road, Anderson, SC 29625

Phone 1-800-525-2579

www.ryobitools.com